

sunways

AU

User Manual

Hybrid Inverter

STH-3K~8KTL

sunways

CONTENTS

1 Preface	5
1.1 Overview	5
1.2 Target Groups	5
2 Safety Instructions	6
2.1 Safety Notes	6
2.2 Statement	6
2.3 Important Safety Matters	7
2.4 Symbols Explanation	8
3 Product Introduction	11
3.1 Basic Features	11
3.2 Appearance Introduction	17
3.3 Display Interface	19
3.4 Packing List	20
4 Product Installation	23
4.1 Selection of Installation Location	23
4.2 Mounting the Inverter (Standard bracket)	25
4.3 Mounting the Inverter (Including L-shaped plate)	27
4.4 Electrical Connection	30
4.5 Communication Connection	47
4.6 Monitoring Device Installation	53
5 Equipment Commission and Stop	54
5.1 Equipment commission	54
5.2 Stop Inverter	55
5.3 Removing of Inverter	55
6 General Operation	56
6.1 Display Operation	56
6.2 Country Code (Safety Code) Setting	60
6.3 Grid Protection settings	61
6.4 Power Quality Response Modes	61
6.5 Fixed power factor setting	62
6.6 Power rate limit setting	63
6.7 Export Limit and Generation Limit	64
6.8 Online Monitoring APP	66
7 Troubleshooting	67
7.1 Fault Messages	67
7.2 PV System for Ground Faults	70
7.3 Maintenance	70
8 Technical Parameters	71

Attention

The products, services or features you purchase are subject to the commercial contracts and terms of Ningbo Sunways technologies Co., Ltd. All or part of the products, services or features described in this document may not be within your purchasing or using scope. Unless otherwise agreed in the contract, the Company shall not make any express or implied declaration or guarantee of the contents of this document.

Due to product version upgrades or other reasons, the contents of this document will be updated periodically. Unless otherwise agreed, this document serves only as a guide to use, and all statements, information and recommendations in this document do not constitute any express or implied guarantee.

» 1 Preface

※ 1.1 Overview

This manual is an integral part of Sunways STH-3K~8KTLseries single-phase high-voltage hybrid inverters (hereinafter referred to as the hybrid inverters). It mainly introduces the assembly, installation, electrical connection, debugging, maintenance and troubleshooting of the products. Before installing and using hybrid inverters, please read this manual carefully, understand the safety information and be familiar with the functions and characteristics of hybrid inverters.

※ 1.2 Target Groups

This manual is applicable to the electrical installers with professional qualifications and the end-users. If there are any problems in the installation process, please call Sunways service telephone at +86 400-9922-958 or email Sunways at service@sunways-tech.com for consultation.

» 2 Safety Instructions

※ 2.1 Safety Notes

- ① Before installation, you should read this manual carefully and follow the instructions in this manual strictly.
- ② Installation operators need to undergo professional training or obtain electrical related professional qualification certificates.
- ③ During the installation, do not touch any parts of the inner part of the inverter except the terminals.
- ④ All electrical installations must conform to local electrical safety standards.
- ⑤ If the inverter needs maintenance, please contact the local designated personnel for system installation and maintenance.
- ⑥ To use this grid-connected inverter for power generation needs the permission of the local power supply authority.
- ⑦ During the operation of the inverter, the surface temperature may be higher and there is a risk of burns. Do not touch.
- ⑧ When installing photovoltaic panels in the daytime, the photovoltaic panels should be covered with opaque materials to avoid the risks and danger of high voltage at the panel end in sunlight.
- ⑨ When wiring the lithium battery terminals, please disconnect the breaker or switch of the lithium battery in case of a physical injury caused by the high-voltage.

※ 2.2 Statement



Sunways Technologies Co.,Ltd. has the right not to undertake quality assurance in any of the following circumstances:



- ① Damages caused by irregular transportation.
- ② Damages caused by incorrect storage, installation or use.
- ③ Damages caused by installation and use of equipment by non-professionals or untrained personnel.

- ④ Damages caused by failure to comply with the instructions and safety warnings in the products and documents.
- ⑤ Damages caused by running in an environment that doesn't meet the requirements which stated in the documents.
- ⑥ Damages caused by operation beyond the parameters specified in applicable technical specifications.
- ⑦ Damages caused by unauthorized disassembly, alteration of products or modification of software codes.
- ⑧ Damages caused by abnormal natural environment (force majeure, such as lightning, earthquake, fire, storm, etc.).
- ⑨ Any damages caused by the installation or operation conditions beyond the stipulated national standard corresponding to the country where the inverter installed.
- ⑩ Products beyond the warranty period.

※ 2.3 Important Safety Matters

The following symbols may appear in this manual, which represent the following meanings:





 Danger	Used to warn of urgent dangerous situations, if not avoided, it could result in death or serious personal injury.
 Warning	Used to warn of potentially dangerous situations, if not avoided, it may result in death or serious personal injury.
 Caution	Used to warn of potentially dangerous situations, if not avoided, it may result in moderate or minor personal injury.

 Attention	Used to transmit the safety warning information about equipment or environment, if not avoided, it may cause equipment damage, data loss, equipment performance degradation or other unpredictable results. "Attention" does not involve personal injury.
 Note	Used to highlight important information, best practices and tips, etc. it's not warning, doesn't involve personal injury and equipment damage information.

※ 2.4 Symbols Explanation





This chapter mainly elaborates the symbols displayed on the hybrid inverter, nameplate and packing box.



▼ 2.4.1 Symbol on the Hybrid Inverter

	Power indicator.
	Grid status indicator.
	Inverter status indicator.
	Battery level indicator.





	Grounding symbol, the inverter casing needs to be properly grounded.
---	--

▼ 2.4.2 Symbol on the Inverter nameplate

	The inverter cannot be disposed of with household waste.
	Please read the instructions carefully before installation.
	Do not touch any internal parts of the inverter until 5 min after being disconnected from the mains and PV input.
	CE mark, the inverter complies with the requirements of the applicable CE guidelines.
	TUV certification.
	Danger. Risk of electric shock!

Symbol	Description
	The surface is hot during operation and no touch is allowed.
	Electric shock hazard, it is strictly forbidden to use the person to disassemble the inverter casing.

2.4.3 Symbol on the Packing box

Symbol	Description
	Handle with care.
	This side up.
	Keep dry.
	Stacked layers.

3 Product Introduction

3.1 Basic Features

3.1.1 Function

Sunways STH series is also known as hybrid inverter or storage inverter, which is mainly used to combine the PV array, lithium battery, loads and power grid to realize intelligent power management and dispatching.

3.1.2 Models

The STH-3K~8KTL series hybrid inverter contains 10 models which are listed below:

STH-3KTL-HSS、STH-3.6KTL-HSS、STH-3KTL-HS、STH-3.6KTL-HS、STH-4.2KTL-HS、STH-4.6KTL-HS、STH-5KTL-HS、STH-6KTL-HS、STH-7KTL-HS、STH-8KTL-HS.

3.1.3 Applicable grid type

The applicable grid types of the Sunways STH-3K~8KTL series are TN-S, TN-C, TN-C-S and TT. When applied to the TT grid, the voltage of N to PE should be less than 30V. See Figure 3-1 for details:

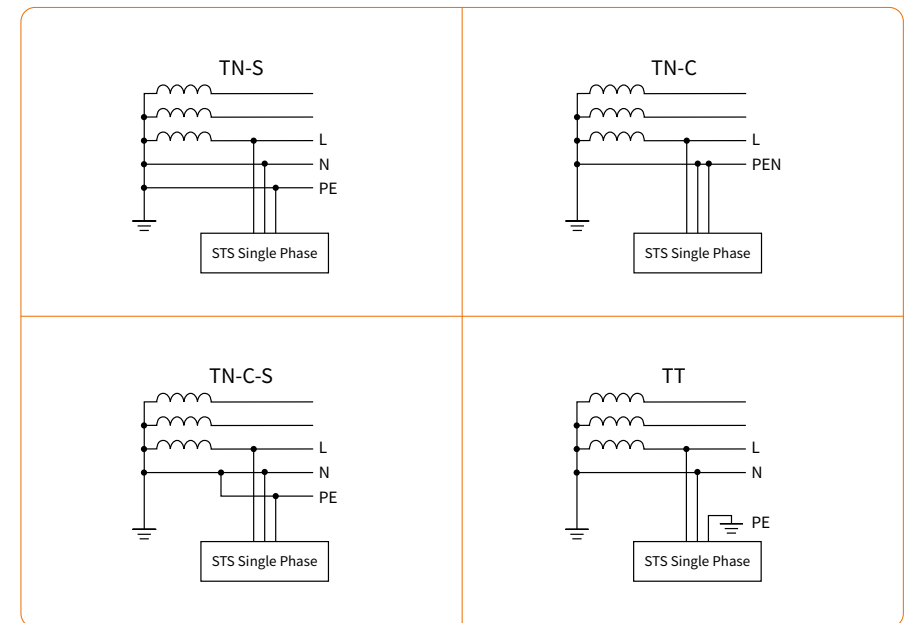

Figure 3-1 Applicable grid types

▼ 3.1.4 Schematic Diagram of Hybrid System

The hybrid solar system is usually composed of the PV array, hybrid inverter, lithium battery, loads and power grid. As shown in the Figure 3-2:

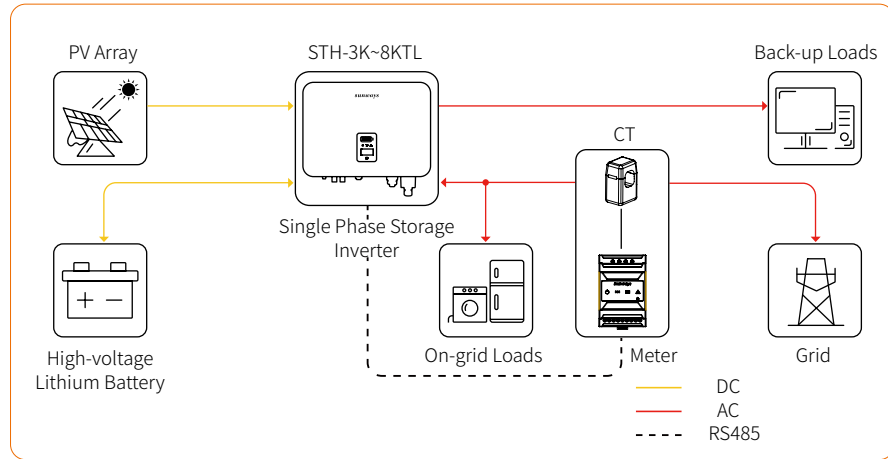

Figure 3- 2 Schematic diagram of hybrid system

▼ 3.1.5 Operation Modes

Sunways STH Hybrid inverter has the following basic operation modes and you can configure the operation mode as per your preference in the App.

Mode 1

In this working mode, when the power from the PV array is sufficient, PV power will supply the loads, battery, and grid by the following sequence:

Loads > Battery > Grid.

PV power will supply the loads first, and second charge the battery, and then feed to the grid. (You can set the power to the grid to 0W if the local grid doesn't allow).

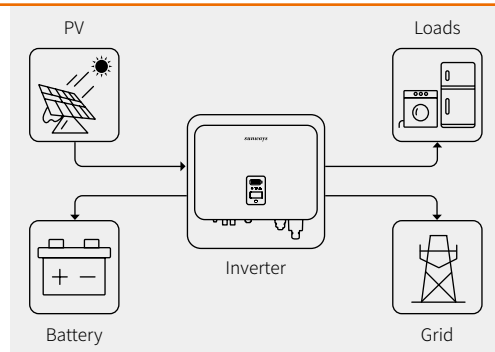

When the PV power is insufficient, the battery will discharge to supply loads, and the grid will join in if the battery is not enough to supply loads.

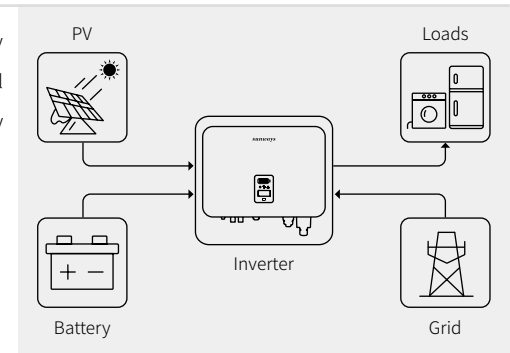

Mode 2

Screen Setting step:

① General Settings → WorkMode Set → General Mode

② Advanced Settings → Peakload Shifting → ON

③ Advanced Settings → SetMaxGrid → XXX (kVA)

APP Setting step:

General Mode → To Set → Peakload Shifting ON → Set Max Grid (kVA)

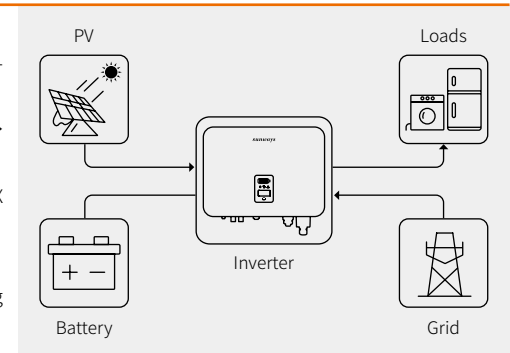

In this working mode, set the Pmax from grid in the App can realize the “Peakload Shifting” .

When the loads consumption more than the Pmax, the power exceeded Pmax (cannot be higher than the inverter max output power) will be supplied by the inverter. Inverter will use power from PV array to supply loads first and battery second if it isn't enough.

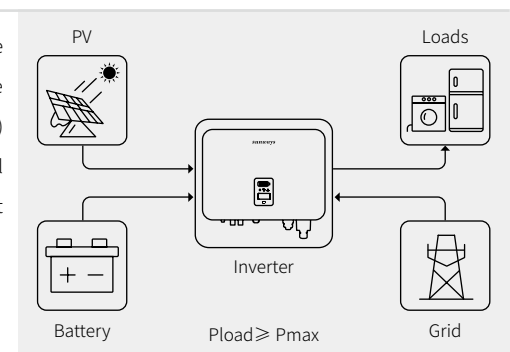

* To realize the “Peakload Shifting” function, the load power that exceeded Pmax has to be within the inverter max output power, otherwise, the inverter will only output the max power which allowed.

Mode 3

In this working mode, the inverter will use the power from PV or grid (Set in the App) to charge the battery until it is fully charged, and as long as the grid is there, the battery won't discharge.

When the grid is cut off, power from PV and battery will supply loads connected in the back-up side (UPS).

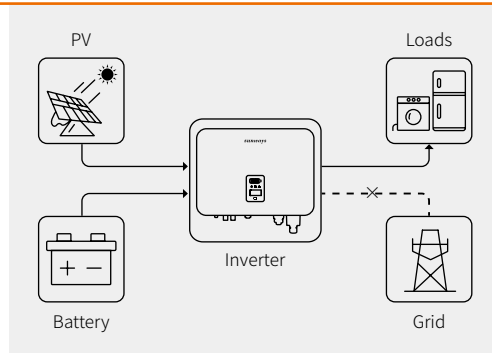

Mode 4

In this working mode, you can set charge/discharge power and time in the App, inverter will use the power from PV or grid (whether to use can be set in the App) to charge the battery in the predetermined period.

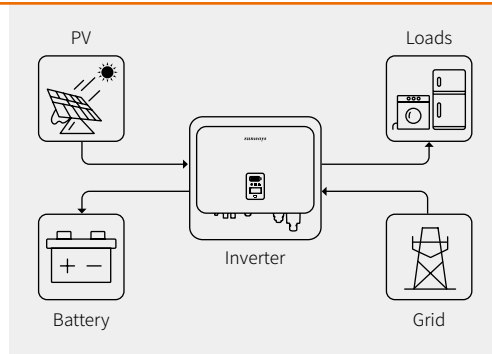

Inverter will use power from PV and battery to supply loads in the predetermined period and the insufficient part will be supplied by the grid.

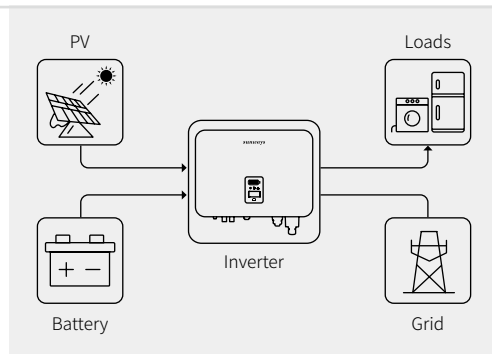

Mode 5

In the purely off-grid mode, power from PV will supply the back-up loads first and then charge the battery if there's surplus.

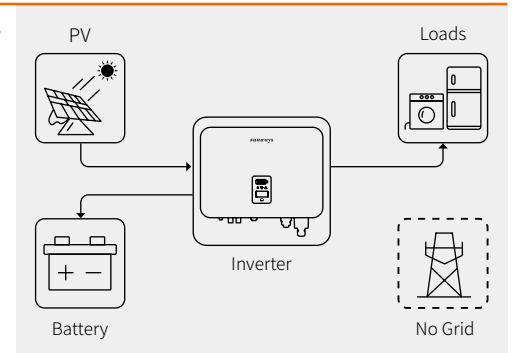

When the power from PV isn't enough, the battery will discharge to supply back-up loads together with PV.

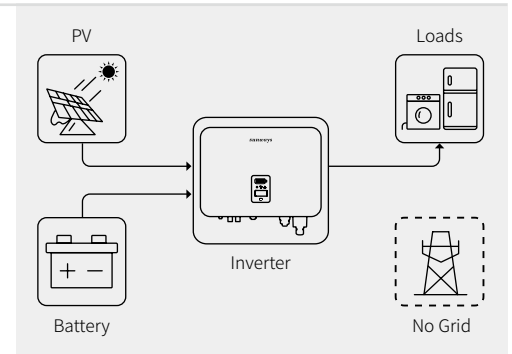

3.1.6 Storage conditions

- ① Inverter must be stored in its original packaging.
- ② The storage temperature should be in the range of -30 °C and + 60 °C, and the relative humidity stored should be less than 90%.
- ③ If a batch of inverters needs to be stored, the height of each pile should be no more than 6 levels.

3.1.7 Handling and Transportation Safety

Handling

- Wear personal protective gears such as protective gloves and shoes when manually moving the equipment.
- To move hybrid inverter by hand, approach to the object, squat down, and then lift

the object gently and stably by the force of the legs instead of your back. Do not lift it suddenly or turn your body around.

Transportation

- Choose sea, roads, air and railway in good conditions for transportation. Avoid tilt or jolt during transportation.
- When transporting the equipment using a pallet truck or forklift, ensure that the tynes are properly positioned so that the equipment does not topple.
- Before moving the equipment, secure it to the pallet truck or forklift using ropes. When moving the equipment, assign dedicated personnel to take care of it.

※ **3.2 Appearance Introduction**

▼ 3.2.1 Inverter front view

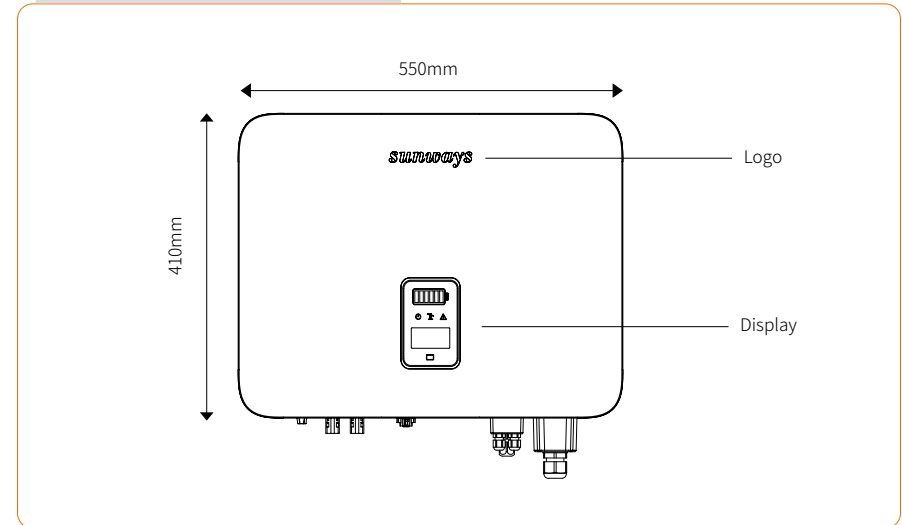

Figure 3- 3 Front view

▼ 3.2.2 Inverter side view

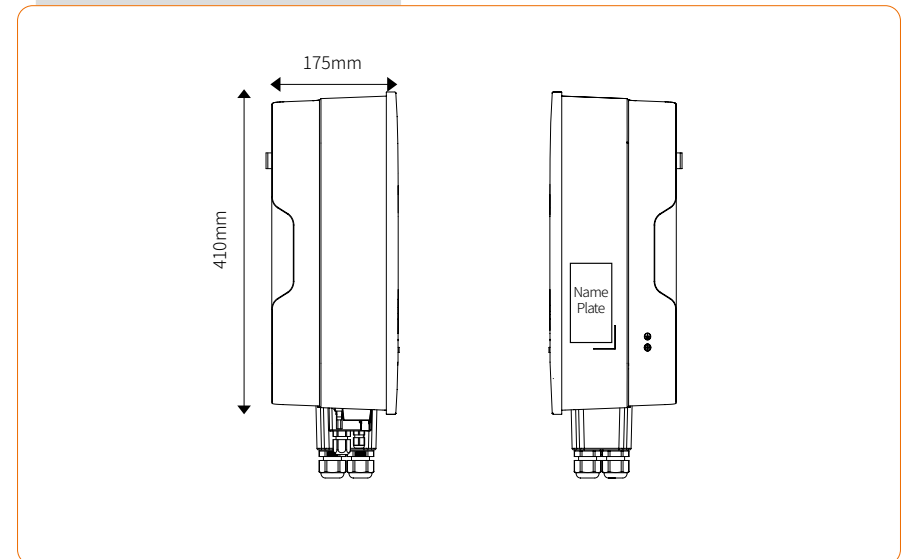

Figure 3- 4 Side view

3.2.3 Inverter bottom view

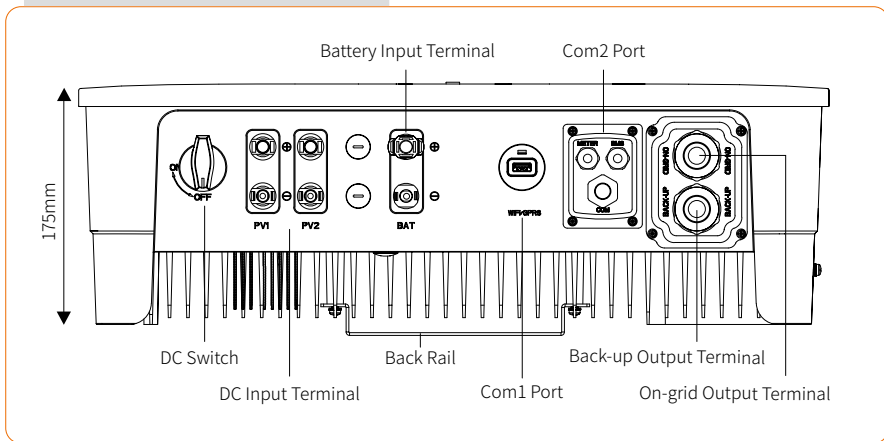

Figure 3-5 Bottom view

3.2.4 Inverter back view

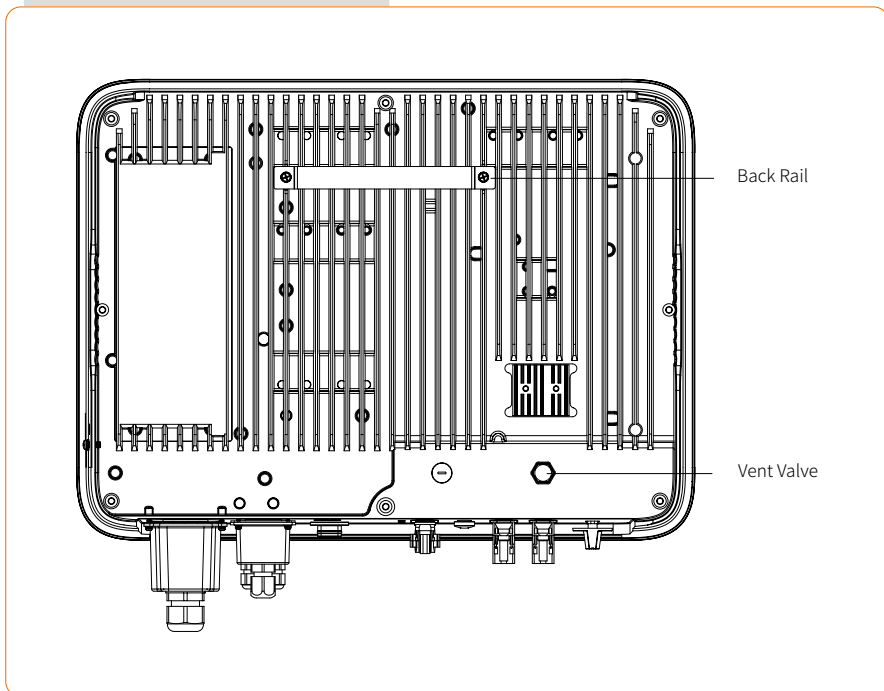

Figure 3-6 Inverter back view

※ 3.3 Display Interface

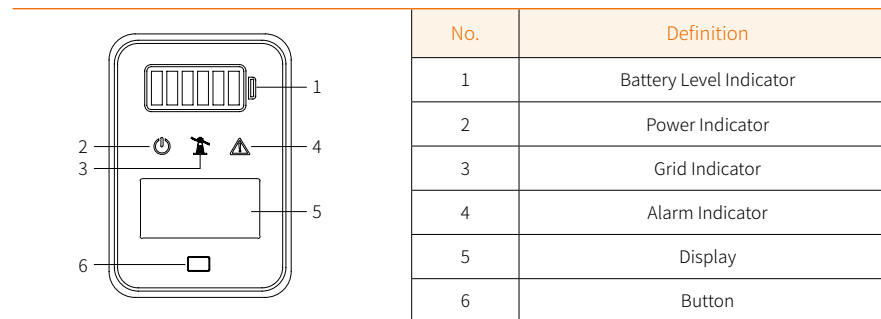

Figure 3-7 Display interface

Item	Indicator	Status	Description
1	Battery Level Indicator	Off	Battery not connected or communication fault.
		Always on	Battery is discharging or waiting, indicator shows battery level.
		Single indicator flash	Battery is charging, indicator shows battery level.
2	Power Indicator	Off	Inverter no AC output.
		Quick flashing	Inverter entered self-test status.
		Slow flashing	Inverter entered waiting status.
		Always on	Inverter works normal.
3	Grid Indicator	Off	Disconnected with grid.
		Slow flashing	Inverter detected grid but not running in on-grid mode.
		Always on	Inverter works in on-grid mode.

Item	Indicator	Status	Description
4	Alarm Indicator	Off	The inverter is running normally.
		Slow flashing	The monitoring device is not connected to the router or is not connected to the base station.
		Quick flashing	The monitoring device is connected to the router or connected to the base station but not connected to the server.
		Orange	A Warning is detected but inverter still working, view the fault info on the display.
		Red	An alarm or fault is detected, view the fault info on the display.
5	Display	On	Display the inverter operation information.
		Off	Display off to save power, press the button to wake up the display.
6	Button	Physical button	Switch display information and set parameters by short press or long press.

※ 3.4 Packing List

The package of the inverter includes the following accessories. Please check whether the accessories in the packing box are complete at the first time when receiving the goods. See Figure 3-8 for the packing list:

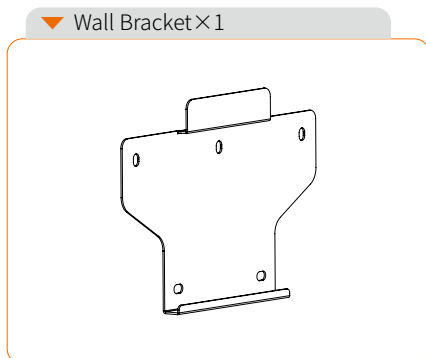
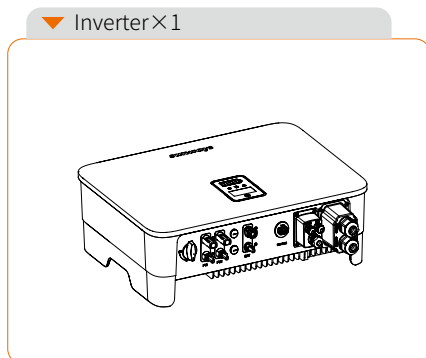
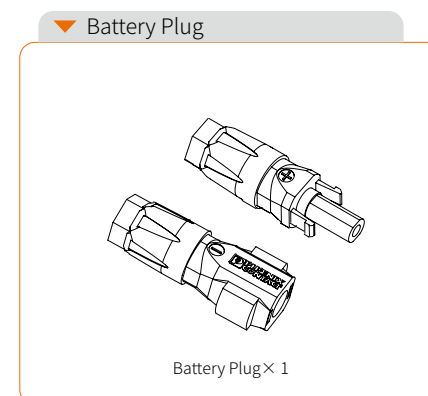
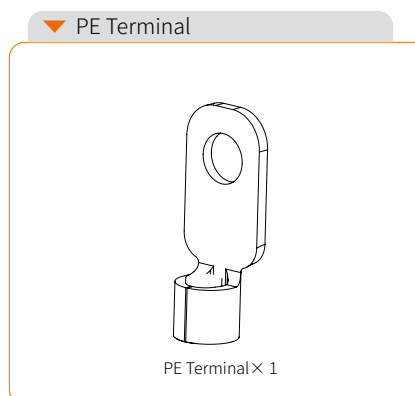
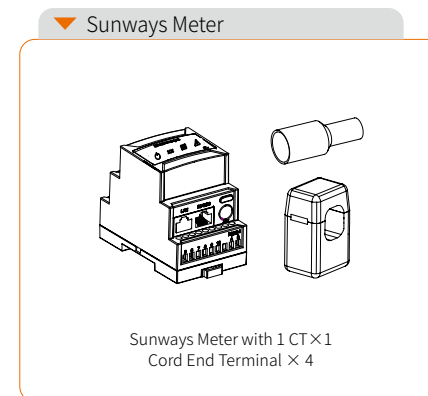
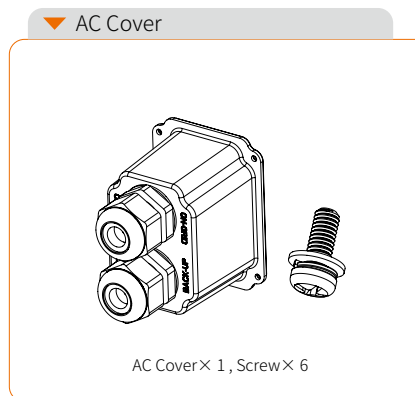
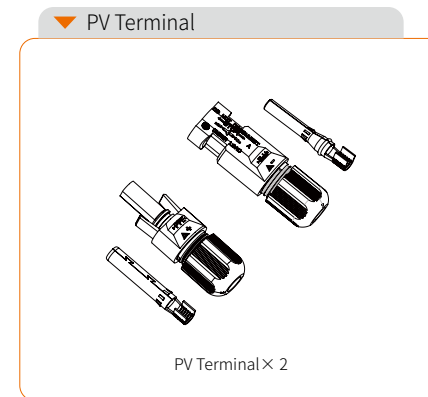
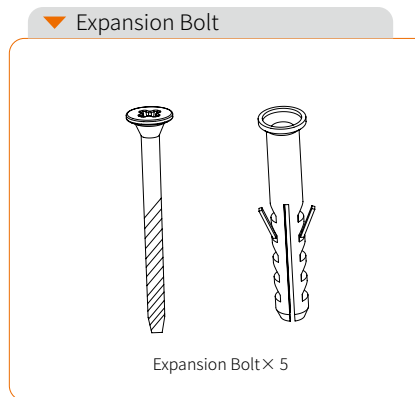

▼ Back-Up Terminal

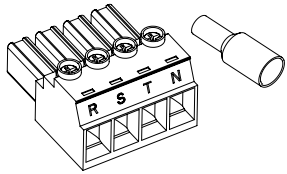

Back Up AC Terminal×1
Cord End Terminal×6

▼ On-Grid Terminal

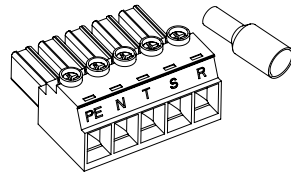

On Grid AC Terminal×1
Cord End Terminal×6

▼ Monitoring Device (Optional)

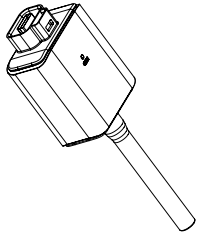

Monitoring Device × 1(Optional)

▼ L-shaped Plate(Optional)

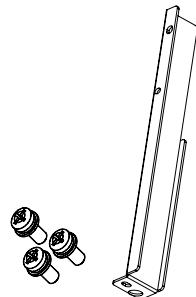

L-shaped Plate×1, Screw× 3

▼ User Guide

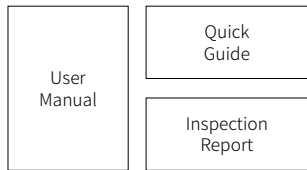

Figure 3- 8 Packing list

» 4 Product Installation

※ 4.1 Selection of Installation Location

The Sunways STH-3K~8KTL series is designed with IP65 protection for indoor and outdoor installations. When selecting an inverter installation location, the following factors should be considered:

- ① The wall on which the inverter is mounted must be strong and can withstand the weight of the inverter for a long time.
- ② The inverter needs to be installed in a well-ventilated environment.
- ③ Do not expose the inverter directly to strong sunlight to prevent the power derating due to excessive temperature.
- ④ The inverter should be installed in a place with shelter to prevent direct exposure to sunlight and rain.
- ⑤ Install the inverter at the eye level for easy inspection of screen data and further maintenance.
- ⑥ The ambient temperature of the inverter installation location should be between -30 ° C and 60 ° C.
- ⑦ The surface temperature of the inverter may reach up to 75 ° C. To avoid risk of burns, do not touch the inverter while it's operating and inverter must be installed out of reaching of children.

▼ 4.1.1 Recommended installation location of the inverter, as shown in Figure 4-1:



Figure 4-1 Recommended installation



Warning

Do not put flammable and explosive articles around the inverter.

▼ 4.1.2 The requirements for inverter installation spacing are shown in Figure 4-2:

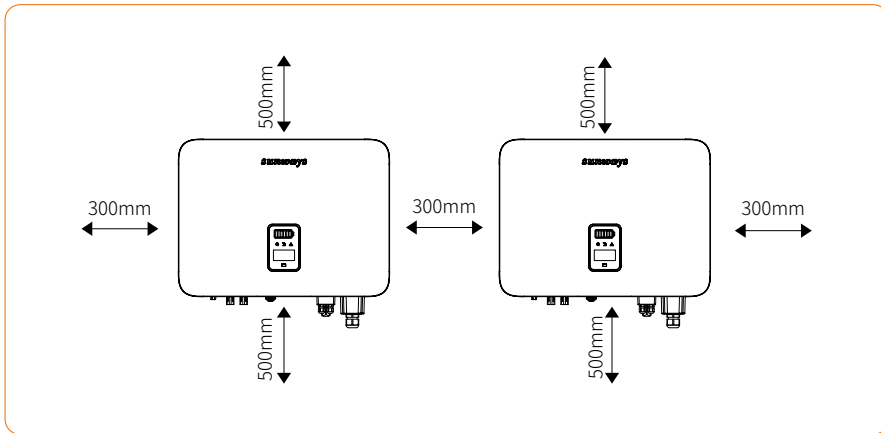

Figure 4-2 Recommended installation space

▼ 4.1.3 The installation angle of the inverter is recommended as shown in Figure 4-3:

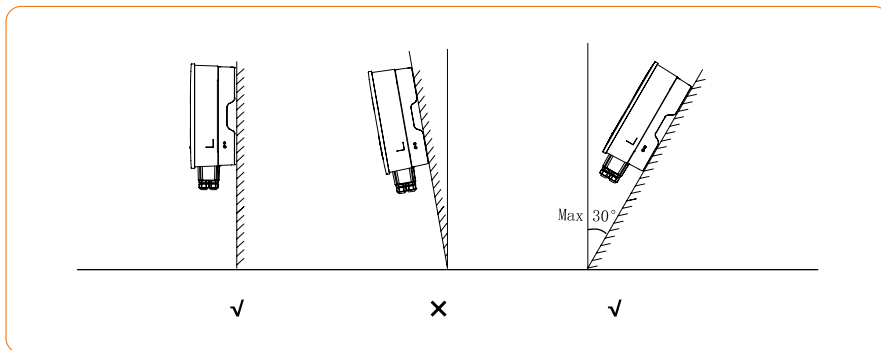

Figure 4-3 Recommended installation angle

※ 4.2 Mounting the Inverter (Standard bracket)

▼ 4.2.1 Wall bracket installation

Dimensions of wall bracket, see Figure 4-4:

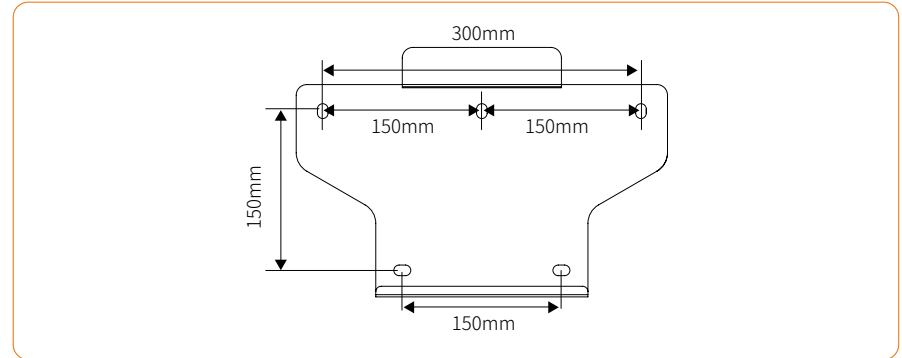

Figure 4-4 Dimensions of wall bracket

① Use the wall bracket as the template to mark the position of 5 holes on the wall. See Figure 4-5 for details:

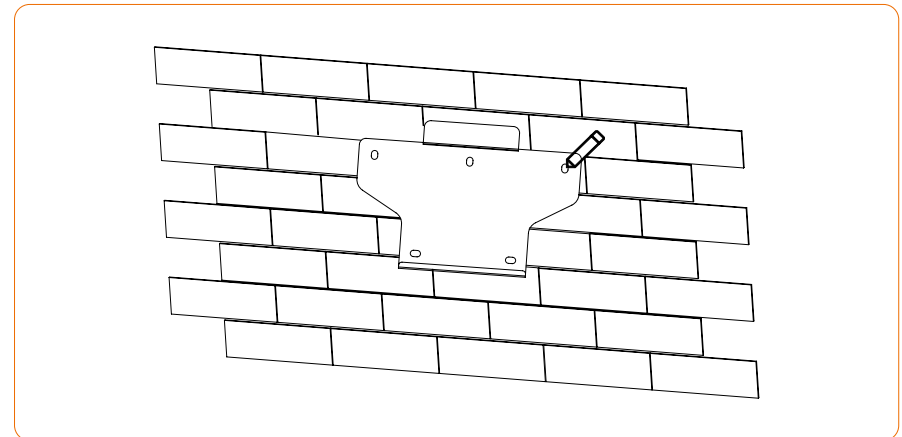

Figure 4-5 Mark the hole position

② Use an electrical drill with 10mm diameter bit to drill 5 holes on the wall and make sure hole depth is 80mm.



Warning

Before drilling, make sure to avoid the buried water tube and electric wires in the wall to avoid danger.

③ Insert the expansion tubes into the holes and tighten them, then fix the bracket onto the wall with expansion screws by using a cross screwdriver, as shown in Figure 4-6:

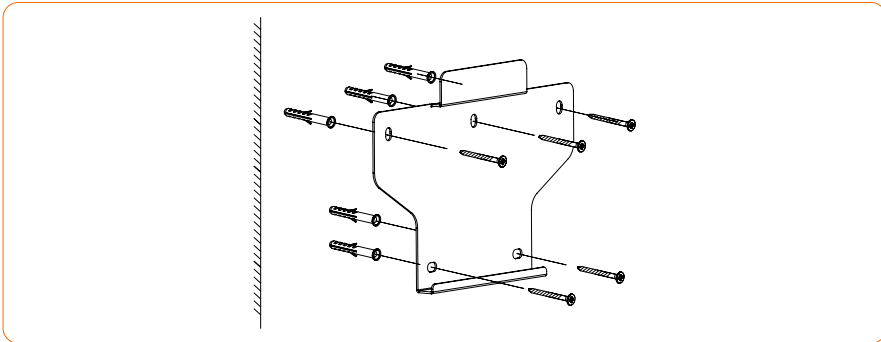

Figure 4-6 Fix the wall bracket

▼ 4.2.2 Mounting the inverter

Lift up the inverter with both hands, hang the back rail on the fixed wall bracket carefully, see Figure 4-7 for details:

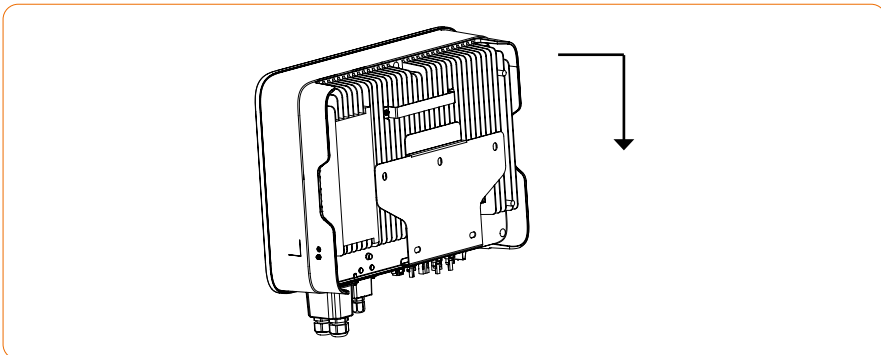

Figure 4-7 Mounting the inverter

※ 4.3 Mounting the Inverter (Including L-shaped plate)

▼ 4.3.1 Wall bracket installation

Dimensions of wall bracket, see Figure 4-8:

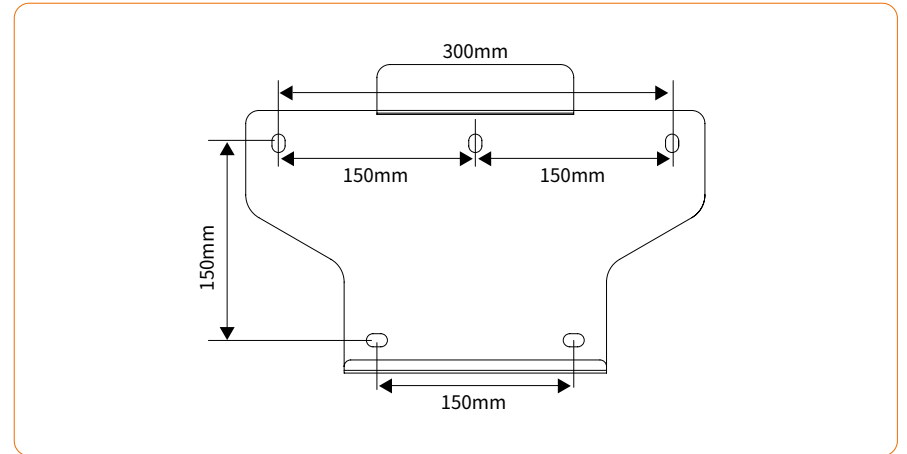

Figure 4-8 Dimensions of wall bracket

① Use the wall bracket as the template to mark the position of 5 holes on the wall. See Figure 4-9 for details:

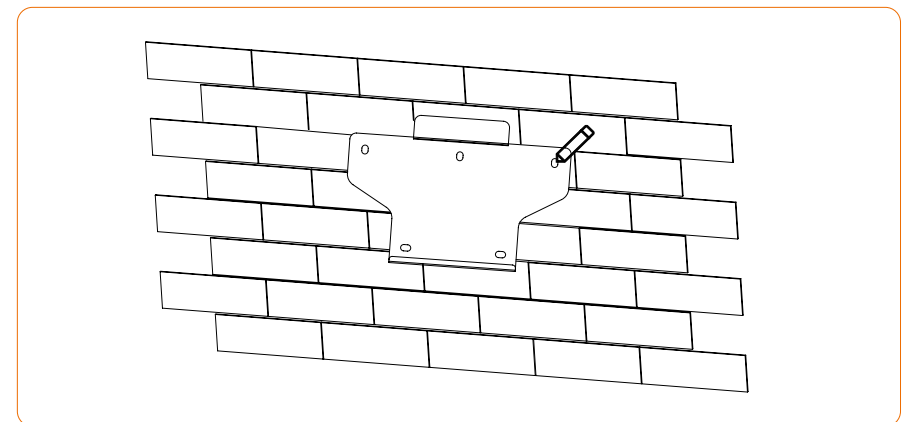

Figure 4-9 Marking hole position using installation bracket

② Bracket assembly

Prepare the two M5 screws and L-shaped plate in the accessory bag, then fix the L-shaped plate to the mounting bracket.

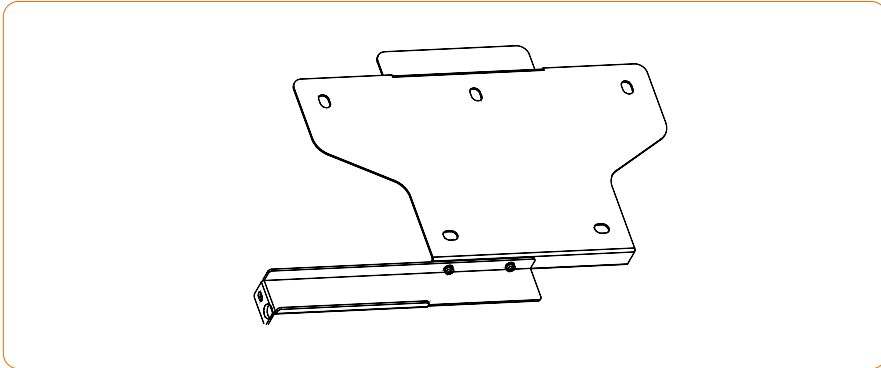

Figure 4-10 Bracket assembly

③ Use an electrical driller with 10mm diameter bit to drill 5 holes in the wall with 80mm depth.



Warning

Before drilling, make sure to avoid any buried water tube and electric wires in the wall.

④ Insert the expansion tubes into the holes and tighten them, then fix the bracket onto the wall with expansion screws by using a cross screwdriver, as shown in Figure 4-11:

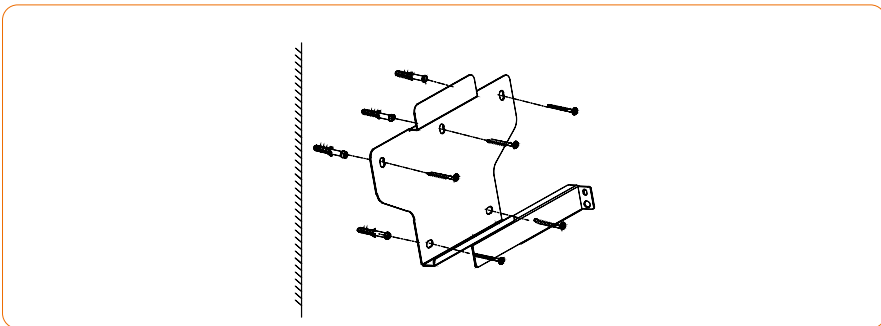

Figure 4-11 Fixing the wall bracket

▼ 4.3.2 Mounting the inverter

Lift the inverter, hang the back rail on the fixed wall bracket carefully. Screws the inverter to the L-shaped plate (The lock is purchased separately). See Figure 4-12 for details:

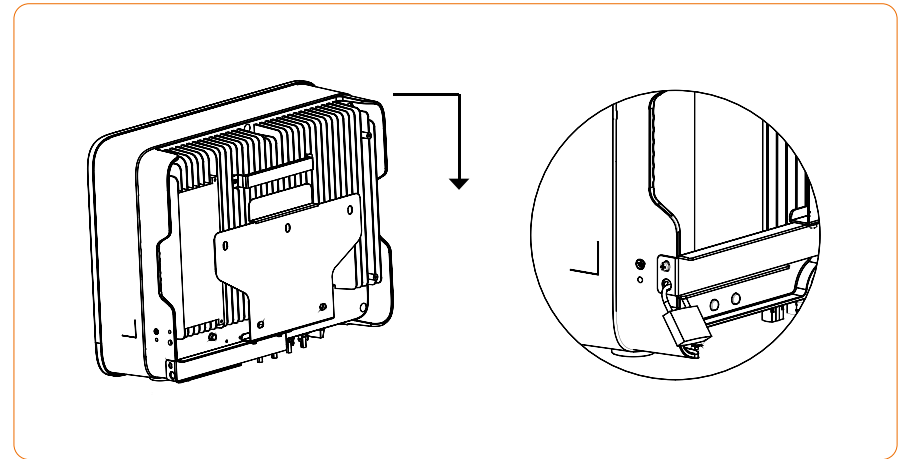







Figure 4-12 Mounting the inverter

※ 4.4 Electrical Connection

 Danger	A high voltage in the conductive part of the inverter may cause an electric shock. When performing any installation on the inverter, make sure that the AC and DC sides of the inverter are completely de-energized.
 Warning	Do not ground the positive or negative pole of the PV string, otherwise it will cause serious damage to the inverter.
 Warning	Static may cause damage to the electronic components of the inverter. Anti-static measures should be taken during the repairing or installation.
 Attention	Do not use other brands or other types of PV terminals other than the PV terminal in the accessory package. Sunways has the right to refuse all damages caused by the mixed-use of terminals.
 Attention	Moisture and dust can damage the inverter, ensure the cable gland is securely tightened during installation. The warranty claim will be invalidated if the inverter damaged by the cable connector not well installed.

▼ 4.4.1 Sunways STH hybrid inverter electrical wiring diagram

This diagram shows Sunways STH-3K~8KTL series hybrid inverter wiring structure and composition, concerning the real project, the installation and wiring have to be in line with the local standards.

Only for Auatralia market: STH3K-8KTL has not been tested to AS/NZS 4777.2:2020 for multiple phase inverter combinations. Combinations should not be used or external devices should be used in accordance with the requirements of AS/NZS 4777.1.

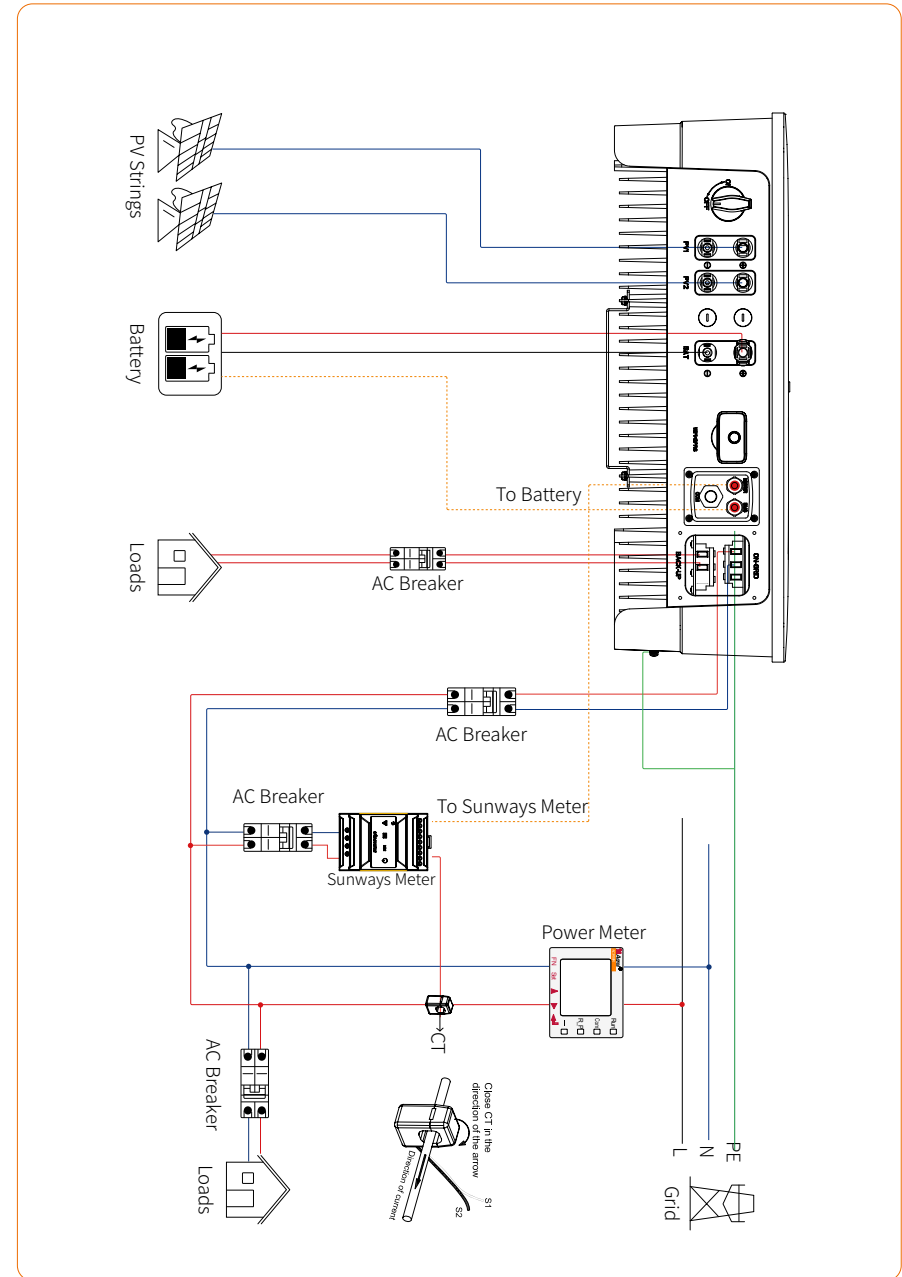

Figure 4-13 Standard wiring diagram

Single inverter wiring diagram

This diagram is an example without special requirement on electrical wiring connection.

Neutral line of AC supply can be isolated or switched.

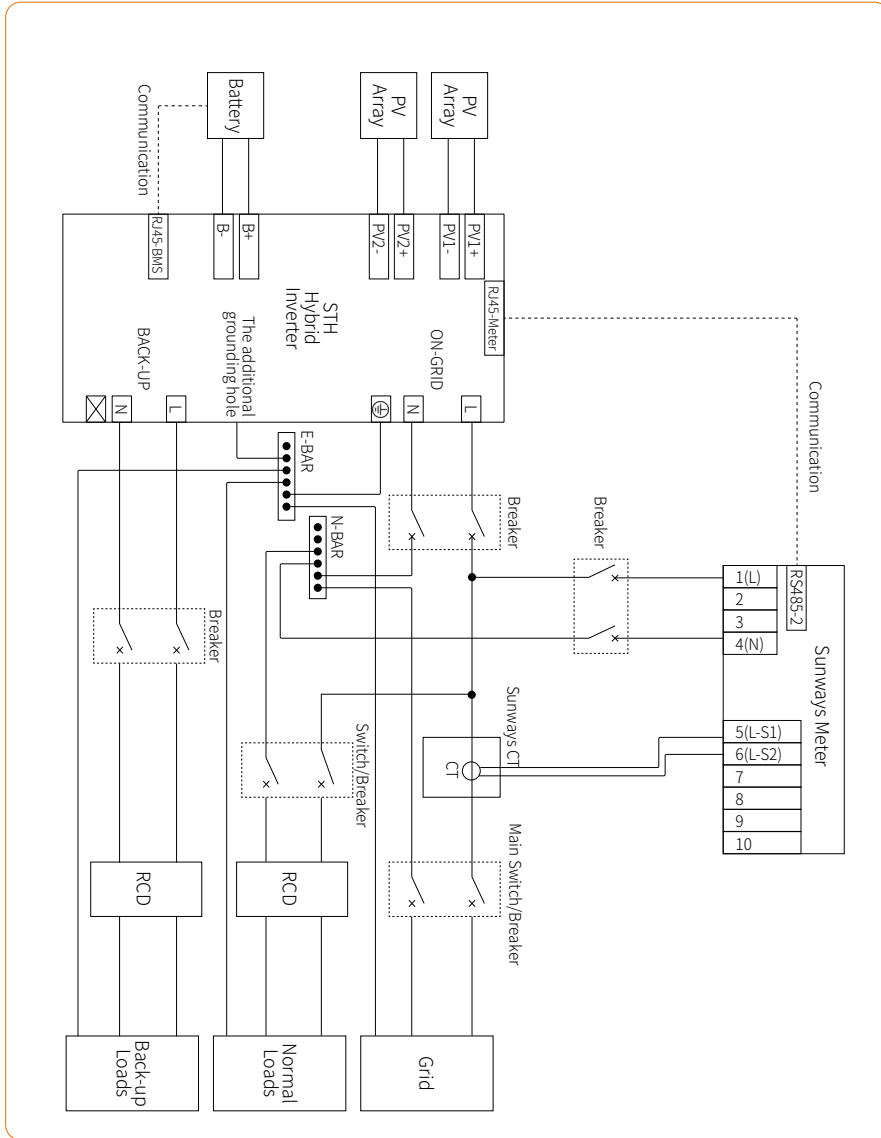

Figure 4-14 Standard wiring diagram

This diagram is an example for Australia and New Zealand. N and PE cables are connected together in the Main Panel for wiring.

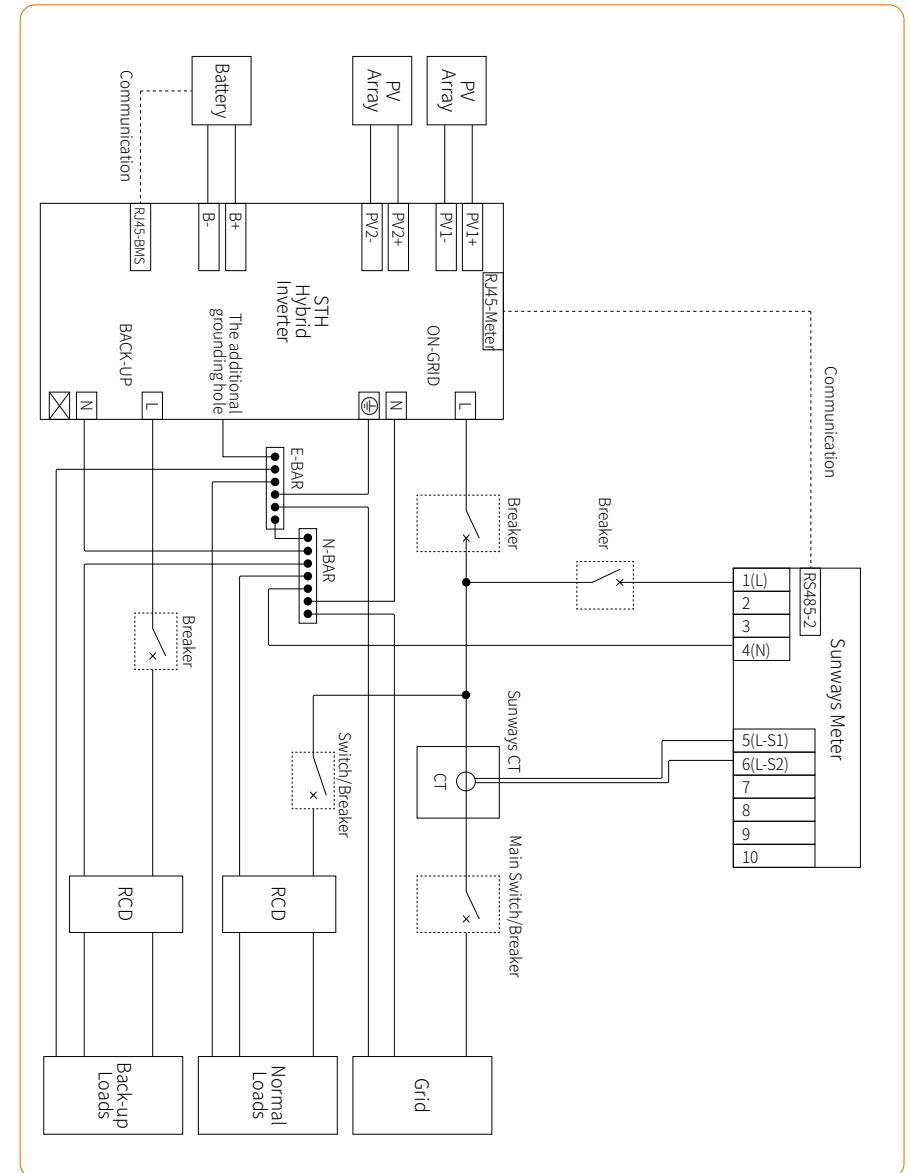

Figure 4-15 Australia wiring diagram

▼ 4.4.2 External ground connection

Connect the inverter and ground bar through PE wire to achieve the purpose of grounding protection. Please always remember wiring the PE wire before wiring other wires.

	<p>Do not connect the N-wire as a protective ground wire to the inverter casing. Otherwise, it may cause electric shock.</p>
	<p>Good grounding is good for resisting surge voltage shock and improving EMI performance. Inverters must be well-grounded. For a system with only one inverter, just ground the PE cable. For a multi-inverter system, all inverters PE wire need to be connected to the same grounding copper bar to ensure equipotential bonding.</p>

Ground terminal connection steps:

- ① The external grounding terminal is located in the lower right side of the inverter.
- ② Fix the grounding terminal to the PE wire with a proper tool and lock the grounding terminal to the grounding hole in the lower right side of the inverter. As shown in Figure 4-16:

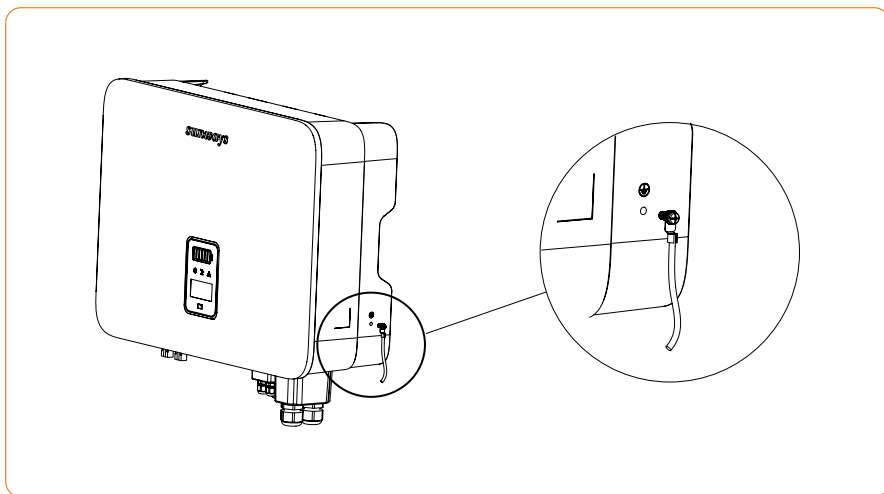

Figure 4-16 Grounding terminal connection

▼ 4.4.3 Inverter PV string connection

1. The following principles must be considered when making electrical connections to the inverter:

- ① Disconnect the AC breaker on the grid side.
- ② The DC switch of the inverter must be turned to the "OFF" position.
- ③ The number and type of the PV panels connected in the two strings of one MPPT must be same.
- ④ Make sure the maximum output voltage of each PV string does not exceed 1000V.

2. DC connector assembly procedures

- ① Select the appropriate photovoltaic cable:

Cable type	Conductor cross-sectional area (mm ²)	
General photovoltaic cable	Scope (mm ²)	Recommended value (mm ²)
	2.5-4.0	4.0

- ② Peel off the DC cable insulation sleeve for 7 mm, as shown in Figure 4-17:

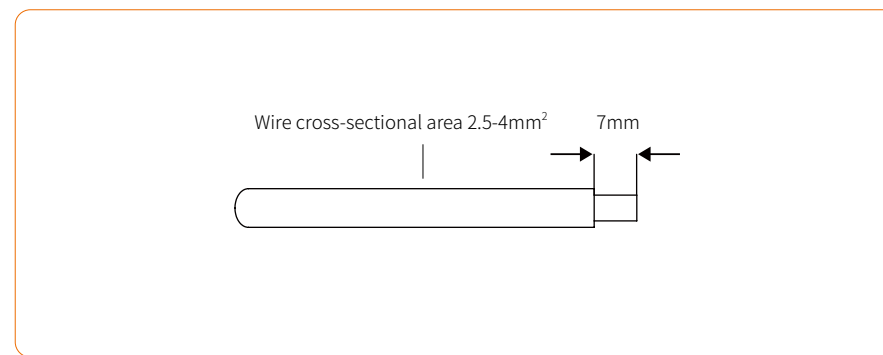

Figure 4-17

③ Disassemble the connector in the accessory bag, as shown in Figure 4-18:

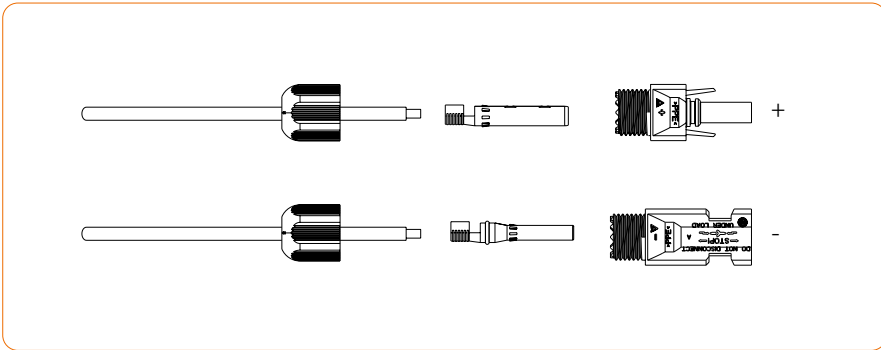

Figure 4-18

④ Insert the DC cable through the DC connector nut into the metal terminal and press the terminal with a professional crimping plier (pull back the cable with some power to check if it's tight enough), as shown in Figure 4-19:

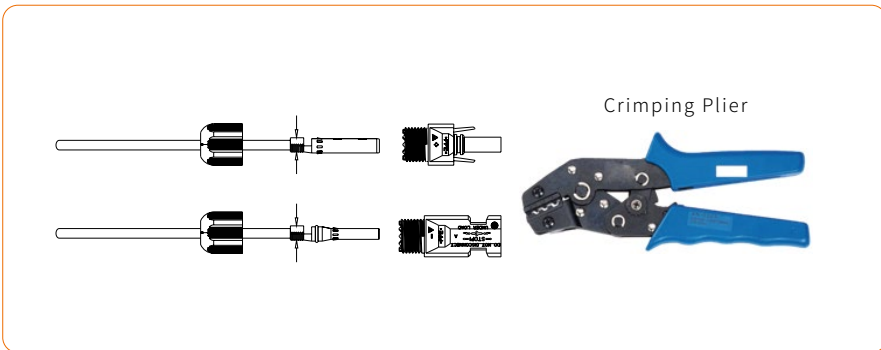

Figure 4-19

⑤ Insert the positive and negative cables into the corresponding positive and negative connectors, pull back the cable to ensure that the terminal is tightly attached in the connector.

⑥ Use an open-end wrench to screw the nut to the end to ensure that the terminal is well sealed, as shown in Figure 4-20:

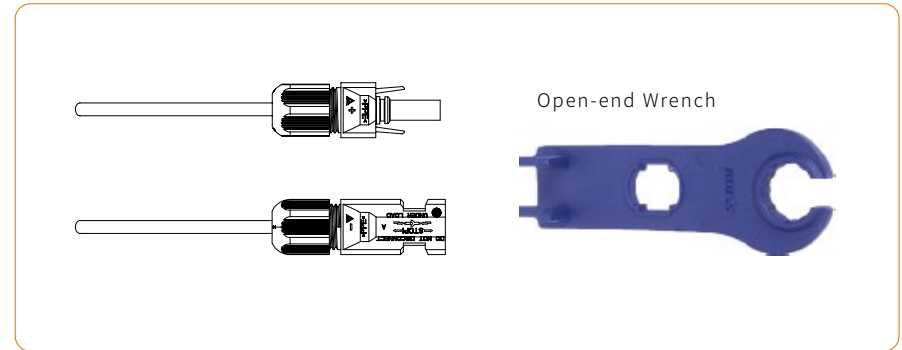

Figure 4-20



Warning

① Before assembling the DC connector, make sure that the cable polarity is correct.

② Use a multimeter to measure the voltage of the DC input string, verify the polarity of the DC input cable, and ensure that each string voltage is within 1000V.

③ Do not connect inverter with functionally earthed PV Arrays.

⑦ Insert the positive and negative connectors into the inverter DC input terminals respectively, and a "click" sound represents the assembly in place, as shown in Figure 4-21:

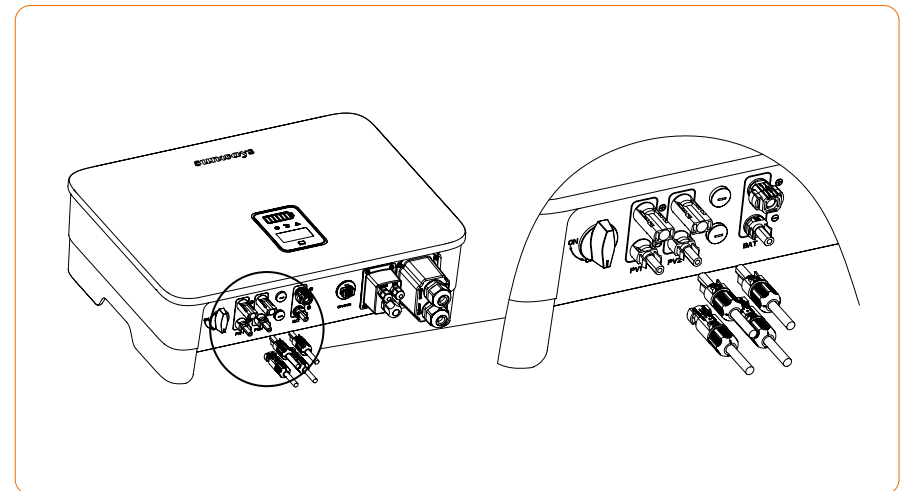

Figure 4-21

▼ 4.4.4 Inverter battery connection

1. The following principles must be considered when making battery connection:

- ① Disconnect the AC breaker on the grid side.
- ② Disconnect the breaker on the battery side.
- ③ Turn the inverter DC switch to the “OFF” position.
- ④ Make sure the maximum input voltage of battery is within the inverter limitation (135~750V).

2. Lithium battery connector assembly procedures

- ① Select an appropriate DC cable.

Cable type	Conductor cross-sectional area (mm ²)	
	Outside diameter (mm ²)	Conductor core section (mm ²)
AWG 10	5.5-8.0	4.0-6.0

- ② Peel off the DC cable insulation sleeve for 15 mm, as shown in Figure 4-22:

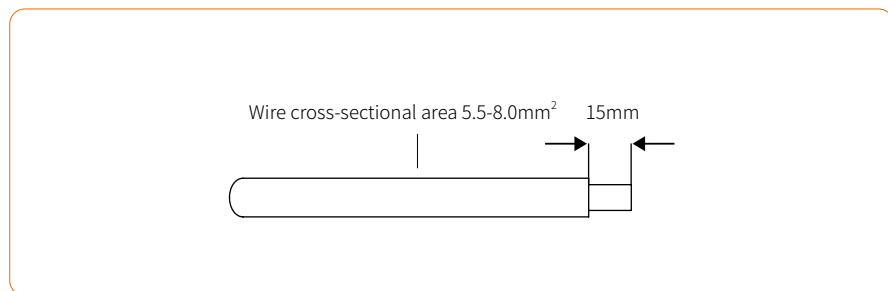

Figure 4-22

- ③ Use a flathead screwdriver to open the clamping bracket in the connector, as shown in Figure 4-23:

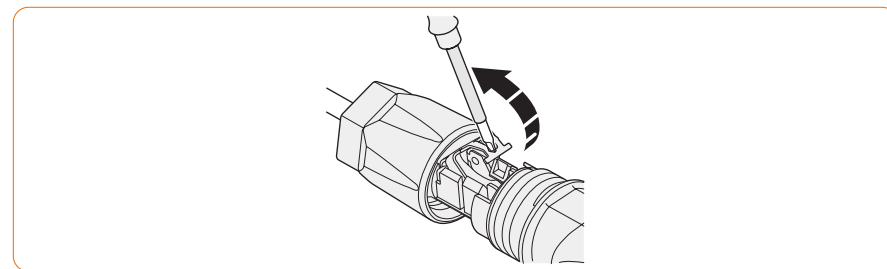

Figure 4-23

- ④ Insert the stripped DC cable to the battery connector deep enough and toggle the clamping bracket to make sure it tightly locked with the stripped cable, as shown in Figure 4-24:

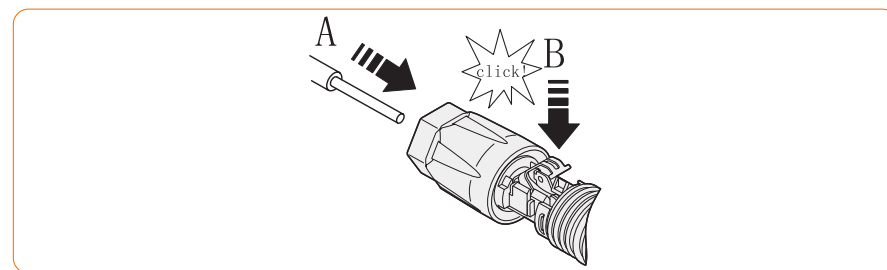

Figure 4-24

- ⑤ Push the battery connector to the thread joint, and use an open wrench to lock the connector in a torsion of 2Nm tightly, as shown in Figure 4-25:

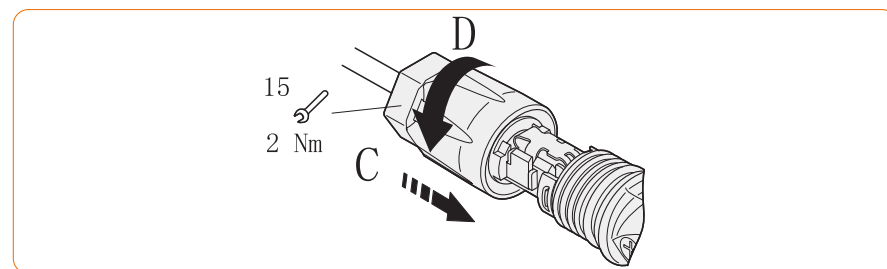

Figure 4-25



Warning

- ① Before making the battery connector, please make sure the polarity of the cable is correct.
- ② Use a multimeter to measure the voltage of the battery pack and make sure the voltage is within the inverter limitation and the polarity is correct.

⑥ Insert the positive and negative connector into the inverter battery terminals respectively, and a “click” sound represents the assembly in place, as shown in Figure 4-26:

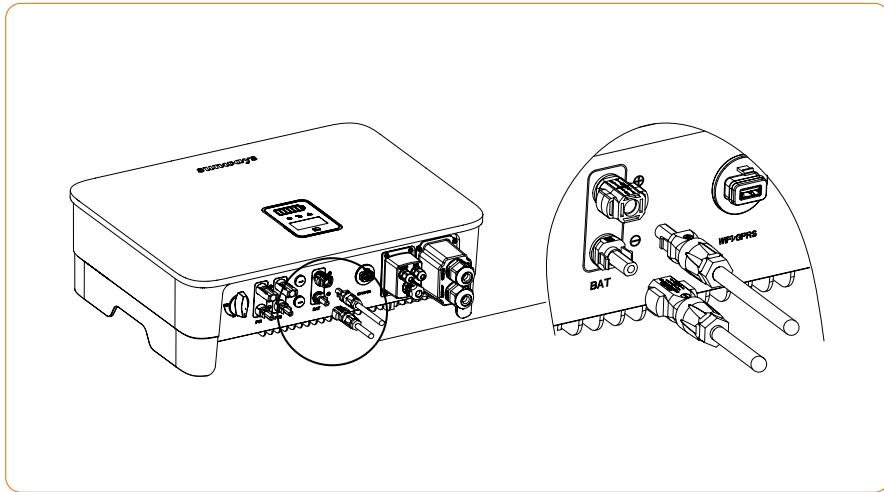

Figure 4-26

▼ 4.4.5 AC output connector connection

1.The following principles must be considered when making AC output connection:

- ① An independent AC breaker is required in both on-grid and back-up output side, and any loads cannot be connected with inverter directly.
- ② Before making the connection of AC cable, please confirm all DC & AC power source are disconnected from the inverter.
- ③ The Sunways STH-3K~8KTL series single-phase high voltage hybrid inverter applies to the single-phase power grid with a voltage of 230V and a frequency of 50/60Hz.
- ④ All Sunways inverters incorporate internal RCD (Residual Current Device) to protect

against possible electrocution in case of a malfunction of the PV array, cables or inverter (DC). The RCD in the Sunways inverter can detect leakage on the DC side. An external RCD is required in some countries. The installer must check which type of RCD is required by the specific local electric codes. Installation of an RCD must always be conducted in accordance with local codes and standards. Sunways recommends the use of a type-A RCD, with a tripping current of 300mA or higher.

2. AC connector assembly procedures

The recommended AC cable and AC breaker for Sunways STH-3K~8KTL series single-phase hybrid inverter are as shown in the following table:

Model	Outside diameter (mm)	Conductor core section (mm ²)	Breaker (A)
STH-3KTL-HSS	12-18	4-10	20
STH-3.6KTL-HSS	12-18	4-10	25
STH-3KTL-HS	12-18	4-10	20
STH-3.6KTL-HS	12-18	4-10	25
STH-4.2KTL-HS	12-18	4-10	25
STH-4.6KTL-HS	12-18	4-10	25
STH-5KTL-HS	12-18	6-10	30
STH-6KTL-HS	12-18	6-10	40
STH-7KTL-HS	12-18	6-10	50
STH-8KTL-HS	12-18	6-10	50

① According to the table above, select an appropriate AC cable, peel off the insulation sleeve of AC cable for 40~60mm, and peel off the sleeve in the conductor core of L/PE/N wires for 8mm, as shown in Figure 4-27:

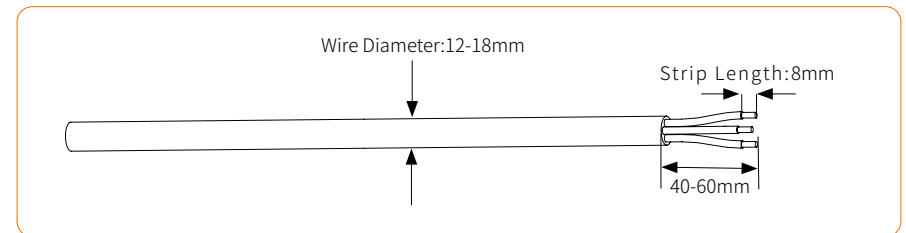

Figure 4-27

② Insert the stripped AC cables through the AC connector cover in the sequence as shown in Figure 4-28:

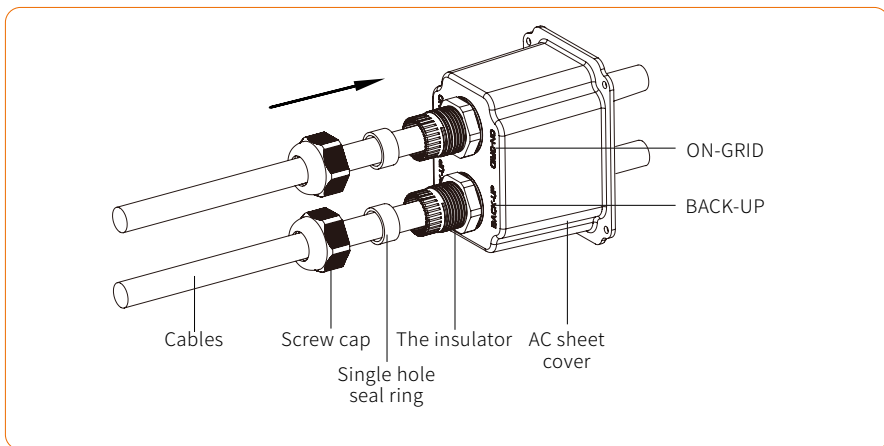

Figure 4-28

③ Put the cord end terminals on the stripped conductors one by one and press with some pressure to make it tightly locked with the conductors, as shown in Figure 4-29:

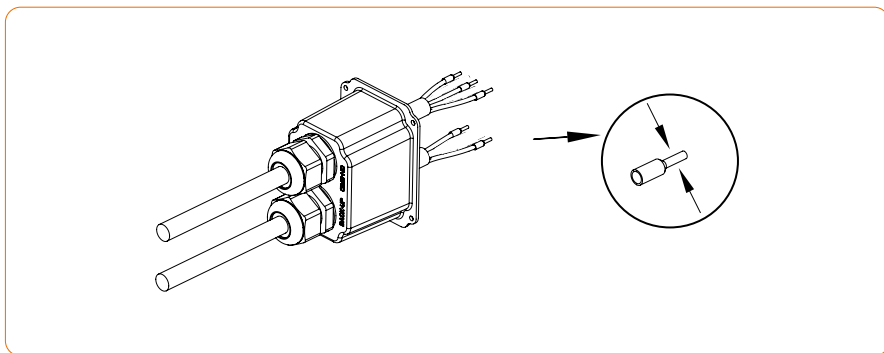

Figure 4-29



Caution

The cord end terminals must be locked tightly, and make sure it won't be loose after a long period of use.

④ Lock the well-pressed cord end terminals into the AC connector in the accessory bag and make sure the cables sequence is in line with the mark on the connector, as shown in Figure 4-30:

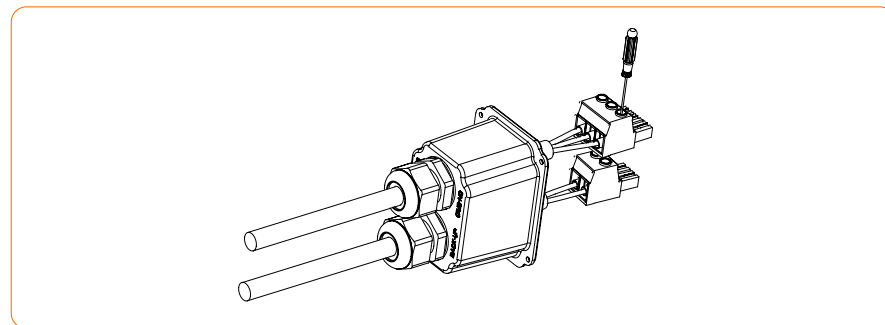

Figure 4-30

⑤ Insert the assembled AC connector to the corresponding AC port in the inverter, as shown in Figure 4-31:

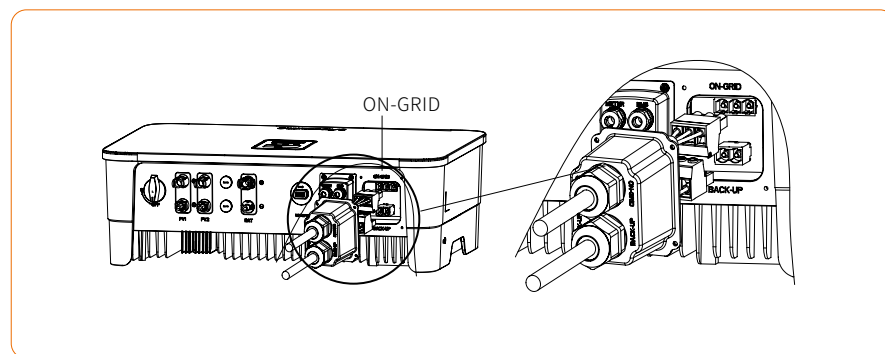

Figure 4-31



Caution

Please distinguish the on-grid and back-up port, and don't mix up the on-grid port and back-up port when making the connection.

⑥ Lock the AC connector cover to the inverter with screws, as shown in Figure 4-32:

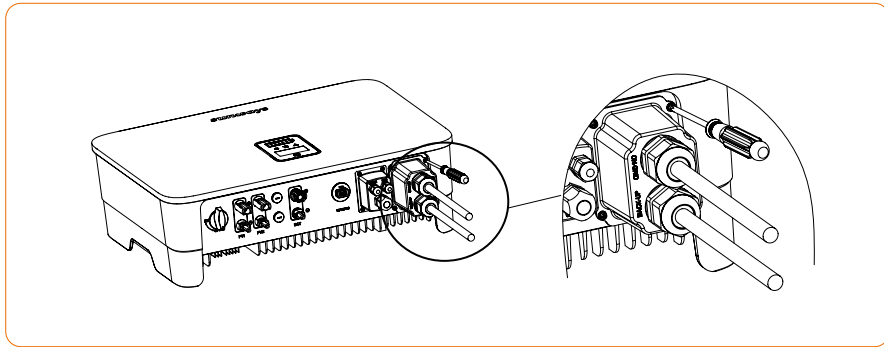

Figure 4-32

⑦ Screw up the rubber ring and anti-water cap to make sure the AC connector is well sealed, as shown in Figure 4-33:

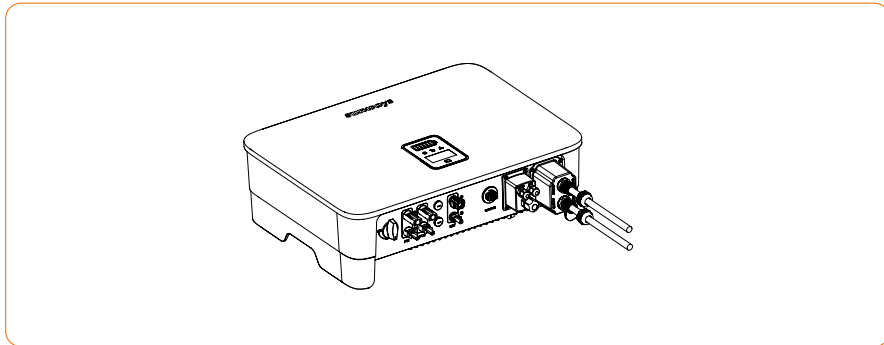

Figure 4-33

▼ 4.4.6 Meter and CT (Residual Current Device) connection

① The current transformer, also called CT, is usually installed on the fire wires between the house loads and the power grid, as shown in Figure 4-34.

The Meter can install in the AC combiner box or other places that are unable to be touched by children. Sunways CT integrated a cable with length of 2m and could be extended to 5m at max.

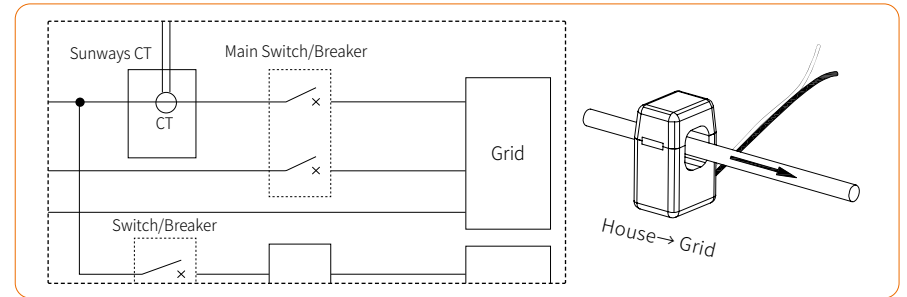

Figure 4-34 CT connection diagram

 Attention	CT installation direction and phase sequence should strictly follow the instruction in the user manual, otherwise, the inverter may not be working normally.
 Attention	The CT has to be corresponding with the port in the meter, and the connection between CT and Meter needs to be reliable, otherwise, the CT measurement accuracy may be affected.
 Note	The rated current of CT in the inverter accessory box is 80A, and the maximum allowed inserted cable diameter is 16mm. If the max current through the CT exceeds the rated current or the cable diameter is wider than 16mm, please contact Sunways for help.

② The CTs have been connected to the Sunways Meter when you received them, and you just need to follow the wiring diagram in the Meter to connect CT, as shown in Figure 4-35.

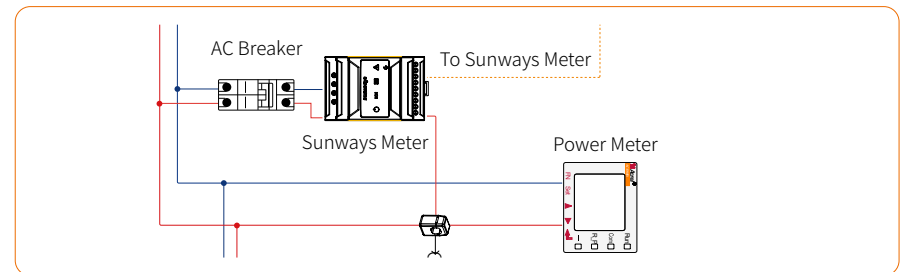

Figure 4-35 Meter wiring diagram

Meter terminals definition as shown in table 4-36:

No.	Definition	Function
1	L	L/N connect to grid to detect power grid voltage
2	NULL	
3	NULL	
4	N	
5	L-S1	Connect CT to detect current
6	L-S2	
7	NULL	
8	NULL	
9	NULL	Communicate with inverter
10	NULL	
RS485-2	RS485	

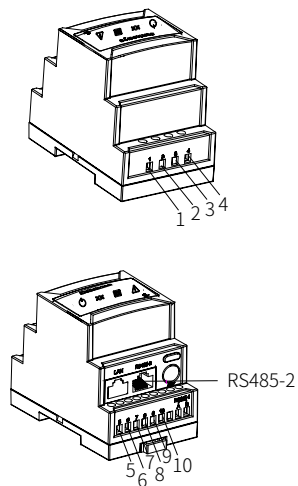

Figure 4-36 Meter terminals definition

Please refer to chapter 4.4.2 for the communication between Meter and inverter.

③ Export limitation & control or generation limit solution

Any further difficulties in export limitation & control or generation limit solution, wiring instructions and configuration, please contact Sunways after-sales at service@sunwaystech.com. You can also refer to chapter 6.7.

※ 4.5 Communication Connection

▼ 4.5.1 Communication wiring illustration

All communication ports are hidden behind the communication terminal at the bottom of inverter which including Meter port, CAN port, BMS port, EMS port, RLYOUT port, DRED port, as shown in Figure 4-37、4-38.

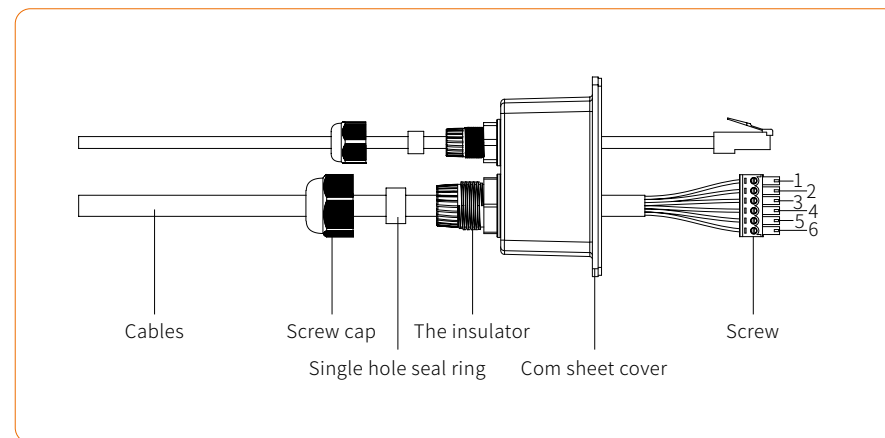

Figure 4-37

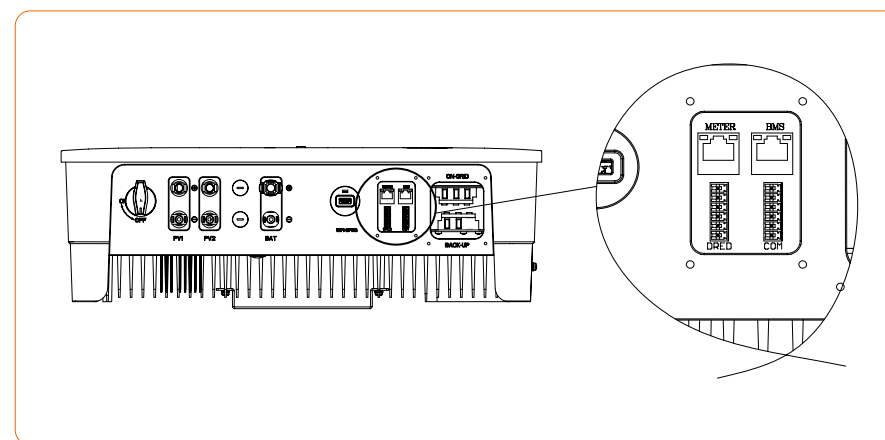

Figure 4-38

Inverter communication interface and definition as shown in table 4-39:

Type	Definition
METER	Communicate with Meter
BMS	Communicate with BMS
DRED	For Australia use/One key to shut off
PARCAN	Parallel CAN communication bus interface
EMS	EMS power dispatching interface
RLYOUT	Dry contact output, a group of normally open contact passive dry contact

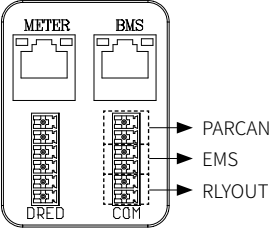

Figure 4-39 Meter terminals definition

Dismantle the cover of the communication ports with a screwdriver, and put all communication cables through the holes and follow the illustration below to make the connection of each communication cables, and when all cables have connected, put back the cover and screw up the anti-water cap of the holes, as shown in Figure 4-40:

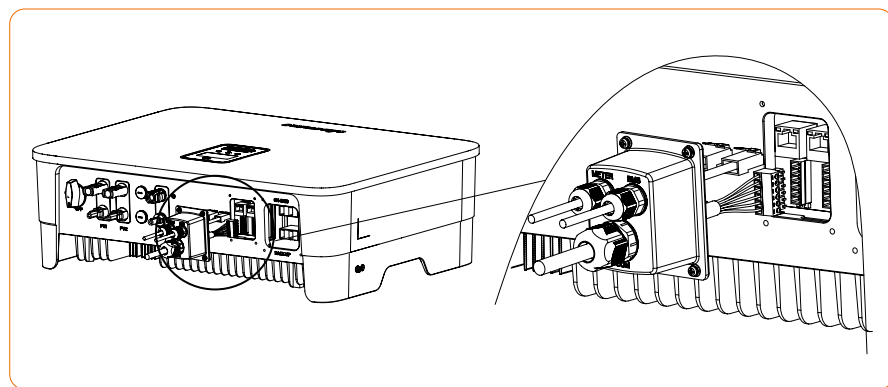

Figure 4-40

4.5.2 Communication between inverter and meter

The communication between meter and inverter is an RJ45 interface cable. A 10M length meter communication cable is already attached to the inverter when you received it and this cable could be extended up to 100M. Insert the RJ45 heads into the meter RS485-2 port which as shown in Figure 4-41.

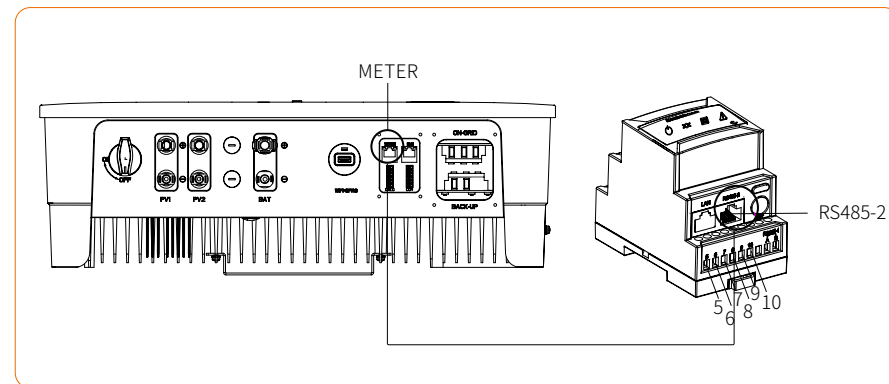

Figure 4-41

RJ45 terminal connection sequence and definition as shown in table 4-42.

No.	Color	Meter Side	Battery Side
1	Orange&White	/	RS485_A
2	Orange	/	RS485_B
3	Green&White	RS485_B	/
4	Blue	/	CAN_H
5	Blue&White	/	CAN_L
6	Green	RS485_A	/
7	Brown&White	RS485_B	/
8	Brown	RS485_A	/

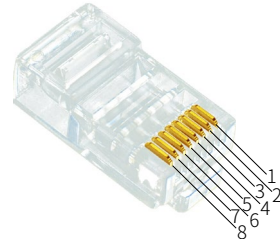

Figure 4-42 RJ45 terminal connection sequence and definition

▼ 4.5.3 Communication between inverter and battery

The communication between meter and inverter is an RJ45 interface cable. A 3M length battery communication cable is already attached to the inverter when you received it, and you just need to insert it to the BMS interface of the inverter and battery.



Note

Before purchasing the battery, you have to make sure the battery you selected is in the battery approval list of Sunways, otherwise, the system may not work properly. Please contact your installer or Sunways service team for confirmation if you're not sure about it.

▼ 4.5.4 Multiple inverters parallel connection/EMS/Relay output dry contact

Multiple inverters parallel connection, EMS and relay output dry contact use the 6pin terminal on the right side, and you can use the matching 6pin terminal in the accessory box to make the connection, as shown in Figure 4-43.

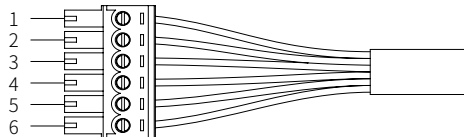

Figure 4-43 Parallel connection/EMS/relay output dry contact terminal

Terminal definition:

No.	1	2	3	4	5	6
Definition	CAN PAR		EMS		RLY OUT	
	CAN_H	CAN_L	RS485_B	RS485_A	RLY_COM	RLY_NO

① An EMS communication cable needs to be connected when to control the operation of a hybrid inverter through the EMS, and communication between EMS and inverter is RS485.

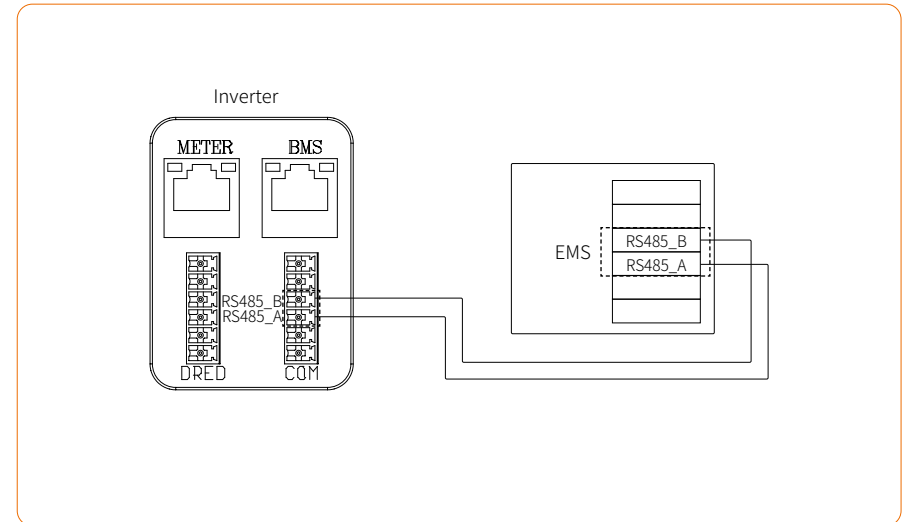

Figure 4-44 EMS communication wiring diagram

② Sunways STH-3K~8KTL series hybrid inverter integrated a set of relay output dry contacts with the contact capacity 230Vac/1A or 30Vdc/1A that are very useful in some special circumstances, such as in the purely off-grid system, it can be used to trigger the backup generator. Please contact your installer or Sunways service team to learn more detailed operation steps.

▼ 4.5.5 DRED Connection

DRED interface is special reserved for Australia and New Zealand according to their safety regulation, and Sunways doesn't provide the DRED device for the customer.

DRED connection uses the 6pin terminal on the left side, and you can use the matching 6pin terminal in the accessory box to make the connection, as shown in Figure 4-45.

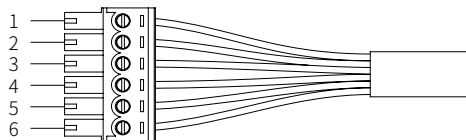

Figure 4-45 DRED terminal

DRED terminal definition:

No.	1	2	3	4	5	6
Definition	COM/DRMO	REFGEN	DRM4/8	DRM3/7	DRM2/6	DRM1/5

▼ 4.5.6 One key to shut off

Sunways STH-3K~8KTL hybrid inverter comes standard with one key to shut off function, and you can use this function by connecting an external switch into the DRED interface if it requires in the installation place. The external switch doesn't include in our accessory box. Please refer to Figure 4-46 for the external switch connection.

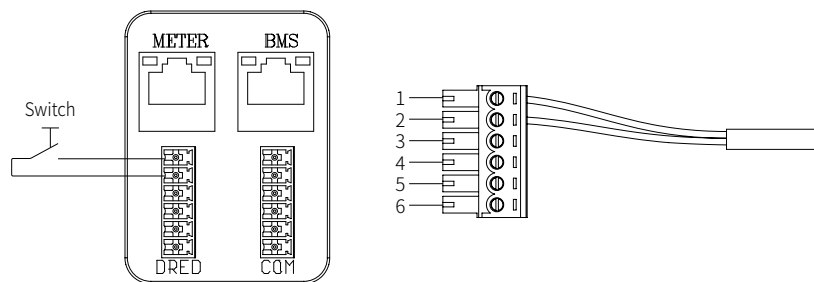

Figure 4-46 One key to shut off terminal

Terminal definition:

No.	1	2	3	4	5	6
Definition	COM/DRMO	REFGEN	/	/	/	/

※ 4.6 Monitoring Device Installation

Sunways STH-3K~8KTL series hybrid inverter can be monitored through either WiFi or LAN, and you can alternatively select according to your preference.

Plug the WiFi or LAN module into the Com1 port in the bottom of inverter by following the direction the side with indicator is up (as shown in Figure 4-47). A slight “click” sound during the installation represents that the assembly is in place.

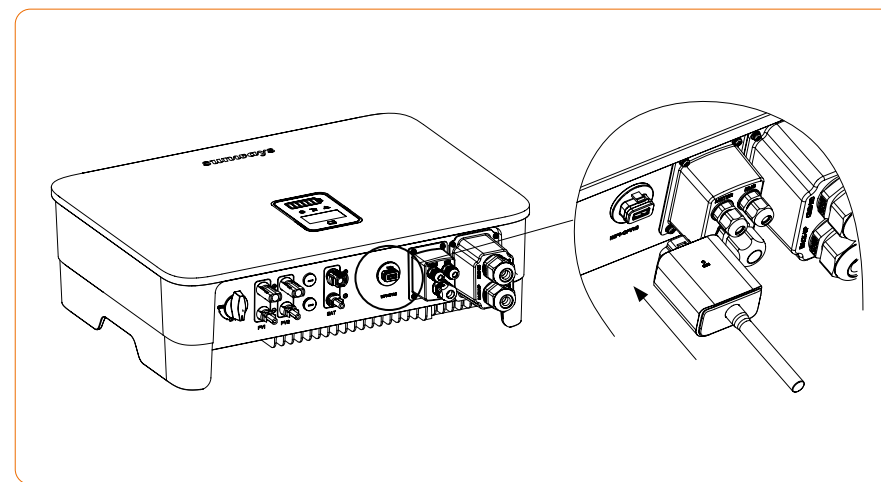

Figure 4-47 Monitoring device installation



Note

- ① The WiFi version module needs to be configured to the router for the first installation. If the router name or password are changed, the WiFi dongle will need to be reconfigured. For details, please refer to the [QUICK INSTALLATION GUIDE] which is attached to the accessory bag.
- ② If DHCP is enabled on the router, the LAN version module does not need to be configured. Otherwise, please refer to the [QUICK INSTALLATION GUIDE] which is attached to the accessory bag.

» 5 Equipment Commission and Stop

※ 5.1 Equipment commission

5.1.1 Verification before power on

No.	Check Items	Acceptance Criteria
1	Hybrid inverter	The product is installed correctly and securely.
2	Installation environment	The product is firmly installed at a clean place that is well-ventilated and easy-to operate.
3	Grounding	The PE cable is connected correctly, securely, and reliably.
4	Switch	The DC switch and all the switches connecting to the hybrid inverters are OFF.
5	Cable connection	The PE, DC input, AC output, and communication cables are connected correctly and securely.
6	Cable ties	Cable ties are intact, routed properly and evenly
7	Unused terminal and port	Unused cable holes are fitted using the waterproof nuts. The electrical conduit holes are sealed.
8	Grid requirements	The voltage and frequency at the connection point meet the inverter grid connection requirements.

5.1.2 Start Inverter

When starting the inverter, follow these steps:

- 1) Turn on the AC breaker first (close the AC circuit breaker).
- 2) Turn the DC switch in the inverter bottom to the “ON” position.
- 3) Turn on the lithium battery switch.
- 4) The inverter will start to check the DC and AC input parameters and self-check, and if everything is normal, the inverter will start to work according to the work mode which you set on the App. The inverter display and indicators will show relative parameters and status. Please refer to LED indicators in part 3.3.

5.1.3 System Commission

For instruction on how to select/active country grid code, protection settings, power quality response mode and region settings as per to AS/NZS 4777.2:2020, please refer to 6.2 Country code (safety code setting), 6.5 Grid protection settings, 6.4 power quality response modes.

※ 5.2 Stop Inverter

When turning off the inverter, please follow the steps below:

- ① Shut off the inverter through the APP or the button on the display first.
- ② Disconnect the breakers on the grid and load side.
- ③ Turn off the battery switch, and disconnect the DC breaker on the battery side (if any).
- ④ Wait 30 seconds and then turn the inverter DC switch to the “OFF” position. At this time, there is remaining power in the inverter capacitor. Wait for 5 minutes until the inverter is completely de-energized before operating.

※ 5.3 Removing of Inverter

When remove and dispose the inverter, please make sure that the inverter is powered off.

Wear proper PPE before any operations. Please follow bellow steps:

- ① Disconnect all the cables, including DC cables, AC cables, communication cables, the communication module, and PE cables.
- ② Remove the inverter from the mounting plate.
- ③ Remove the mounting plate.
- ④ Store the inverter properly. If the inverter needs to be used later, ensure that the storage conditions meet the requirements.

6 General Operation

6.1 Display Operation

When the inverter is turned on, the following interfaces will be displayed on the OLED display, and you can check the information and modify the parameters of the inverter by short or long pressing the button. Please refer to the following display operation flow for details:

6.1.1 Main Window and General Setting

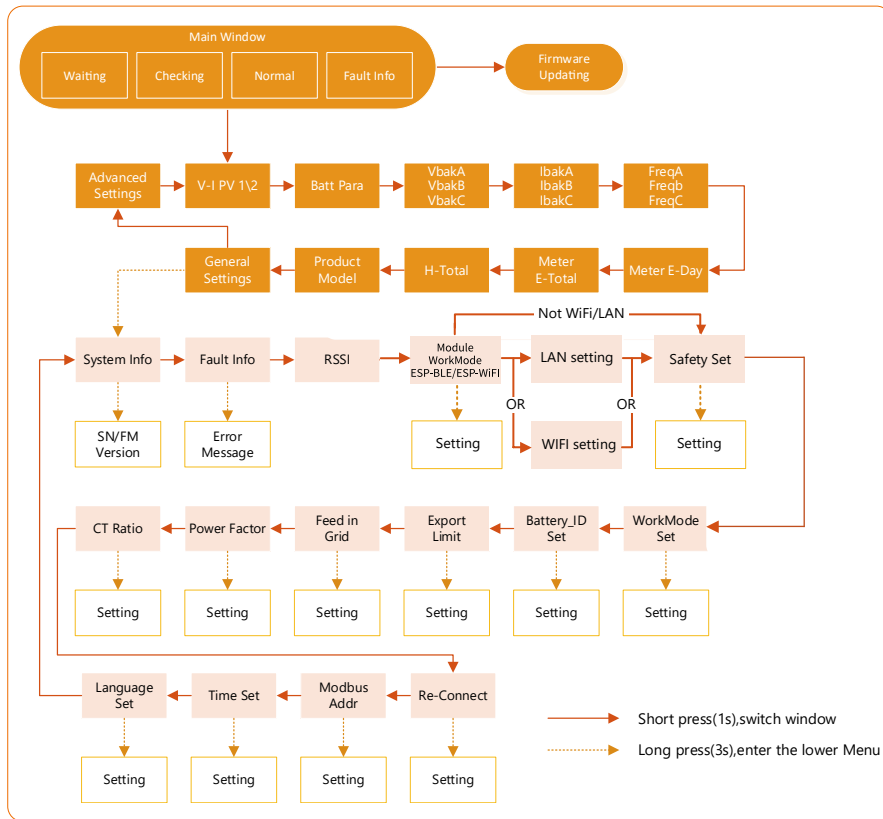

Tip: After every setting completed, wait for 10 seconds and the inverter will automatically save your settings or modifications.

6.1.2 Advanced Setting

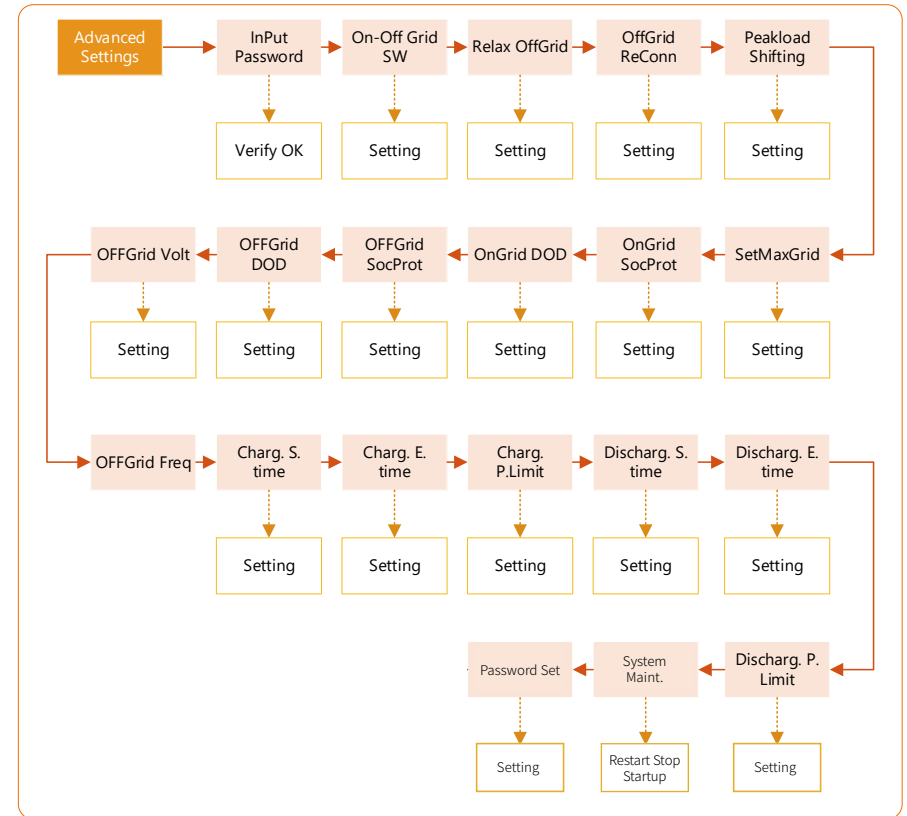

Inverter Display Abbreviation and Complete Name Reference Table

Abbreviation	Complete Name
Work Mode	Current Work Mode / Work Mode Setting
Peakload Shifting	Peakload Shifting Function Switch
SetMaxGrid kVA	Set max allowed power from grid (under the condition of Peakload Shifting is on)
OnGrid SocProt.	OnGrid Battery Soc Protection
OnGrid DOD	OnGrid Discharge of Depth
OffGrid SocProt.	OffGrid Soc Protection
OffGrid DOD	OffGrid Discharge of Depth
OffGrid Volt	OffGrid Voltage Setting
OffGrid Freq	OffGrid Frequency Setting
Discharg.S.time	Discharge Start Time (Available in Economic Mode)
Discharg.E.time	Discharge End Time (Available in Economic Mode)
Discharg.P.Lim.	Discharge Power Limit (Available in Economic Mode)
Charg. S.time	Charge Start Time (Available in Economic Mode)
Charg. E.time	Charge End Time (Available in Economic Mode)
Charg. P.Lim.	Charge Power Limit (Available in Economic Mode)
Unbalan. Output	OnGrid 3-Phase Unbalanced Output Switch
On-Off Grid SW	Off-grid Function SW (Inverter will automatically switch to off-grid mode to ensure the back-up side power supply when the grid is abnormal or off)
Relax OffGrid	Reduce the switching sensitivity of the On/Off-grid (applied to the places where the grid is unstable or inverter always entered off-grid mode for some reasons)
OffGrid ReConn.	When the power grid is off, the inverter can automatically restart the back-up output after a fault or overloading protection occurred if the Off-grid Restart is ON. Otherwise, the back-up output needs to be restarted manually
FW Updating	Firmware Updating

Abbreviation	Complete Name
E-Day	Daily Energy Generation
E-Total	Total Energy Generation
H-Total	Total Generating Hours
System Info	System Information
FW Version	Firmware Version
SN	Series Number
Fault Info	Fault Information
RSSI	Received Signal Strength Indicator
WiFi Reset	WiFi Reset
WiFi Reld	WiFi Reload, to reload the WiFi module to factory settings
Export Limit	On-Grid Export Limit Function Switch
Feed in Grid	Set the percentage of the power that is allowed to feed to the grid
Re-Conect	Fault Reconnection Time
CT Ratio	Current Transformer Ratio Setting
Modbus Addr	Modbus Address Setting
Battery_ID Set	Set Battery Model
System Maint.	System maintenance, includes inverter stop and run, system restart

※ 6.2 Country Code (Safety Code) Setting

Please set "Country code (Safety code)" under the menu "Safety Set" in "Advanced Settings".

Please follow this flow chart to set "Country code (Safety code)":

The country grid code and region settings are password protected. User should be able to view but not edit the country codes. If you are installer, please contact importer for password. You can also call Sunways service telephone at +86 400-9922-958 or email Sunways at service@sunways-tech.com for password.

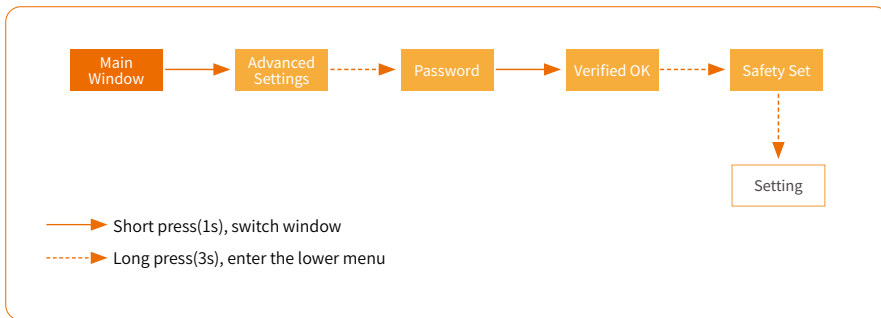

Note
For compliance with AS/NZS 4777.2:2020, please select from Region A/B/C New Zealand. Please contact your local grid operator for which region to select.

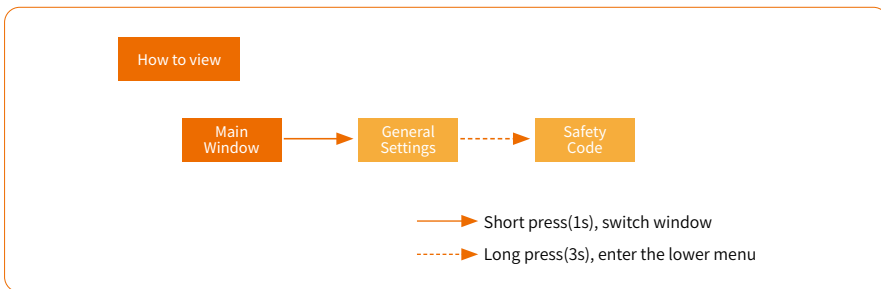

※ 6.3 Grid Protection settings

This mode can be enabled via the configuration software. It is enabled by default in some regions, such as AU market. For information on how to change default setpoints please contact Sunways Technical Support at service@sunways-tech.com. User has access to view the grid protection status in Sunways Portal APP. Please refer to the following steps.

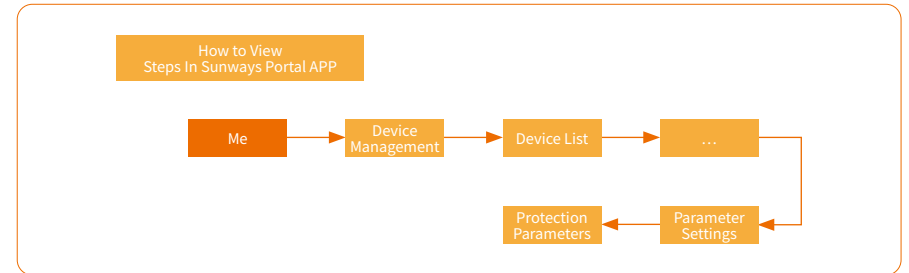

※ 6.4 Power Quality Response Modes

Through the host computer software, set the ON/OFF state of the power quality response mode to enable/disable this function. The default for this function in Australia is the ON state. User has access to view the power quality response mode status in Sunways Portal APP. Please refer to the following steps.

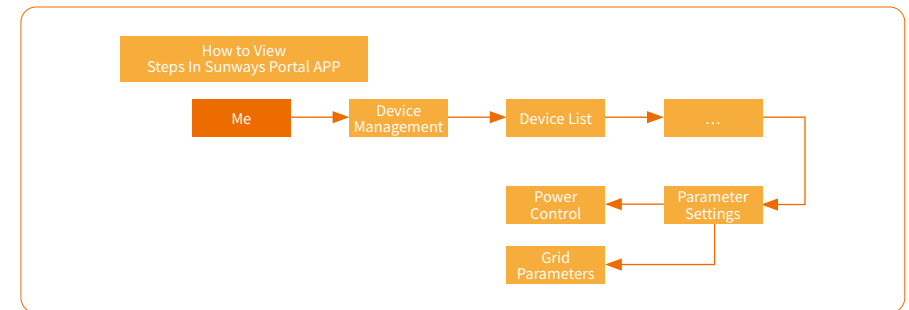

▼ 6.4.1 Power derating for voltage variation (Volt-Watt mode)

This mode can be enabled via the configuration software. It is enabled by default in some regions, such as AU market. For information on how to change default setpoints please contact Sunways Technical Support at service@sunways-tech.com.

▼ 6.4.2 Reactive power regulation for voltage variation (Volt-VAr mode)

This mode can be enabled via the configuration software. It is enabled by default in some regions, such as AU market. For information on how to change default setpoints please contact Sunways Technical Support at service@sunways-tech.com.

▼ 6.4.3 Reactive power mode

This mode can be enabled via the configuration software. It is enabled by default in some regions, such as AU market. For information on how to change default setpoints please contact Sunways Technical Support at service@sunways-tech.com.

※ 6.5 Fixed power factor setting

Please set “Power Factor” under the menu “Power Factor” in “Advanced Settings”.

Please follow this flow chart to set “Power Factor”:

The “Power Factor” settings are password protected. User should be able to view but not edit. If you are installer, please contact importer for password. If there are any problems in the installation process, please call Sunways service telephone at +86400-9922-958 or email Sunways at service@sunways-tech.com for consultation.

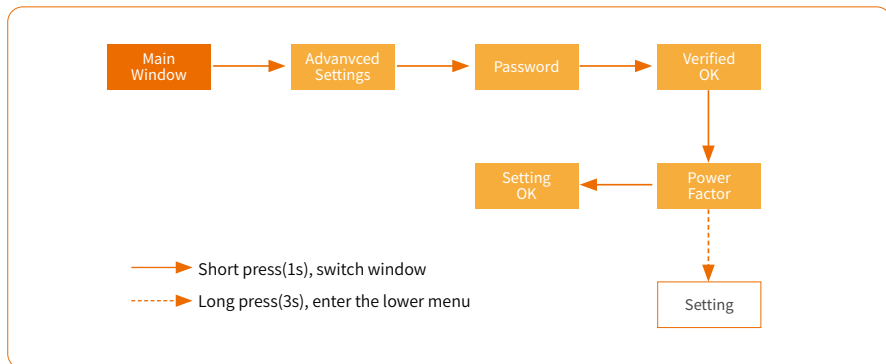

※ 6.6 Power rate limit setting

Please set “Power rate limit ” under the menu “Power rate limit” in “Advanced Settings”.

Please follow this flow chart to set “Power rate limit”:

The “Power rate limit ” settings are password protected. User should be able to view but not edit. If you are installer, please contact importer for password. If there are any problems in the installation process, please call Sunways service telephone at +86400-9922-958 or email Sunways at service@sunways-tech.com for consultation.

Enable the Power rate limit function by short pressing or long pressing the button on the inverter screen.

Set the percentage of the power that allowed to ramp up, when set to XXX%Pn/min, it means that the maximum power allowed to ramp up is XXX%Pn/min of the inverter’s rated output power.

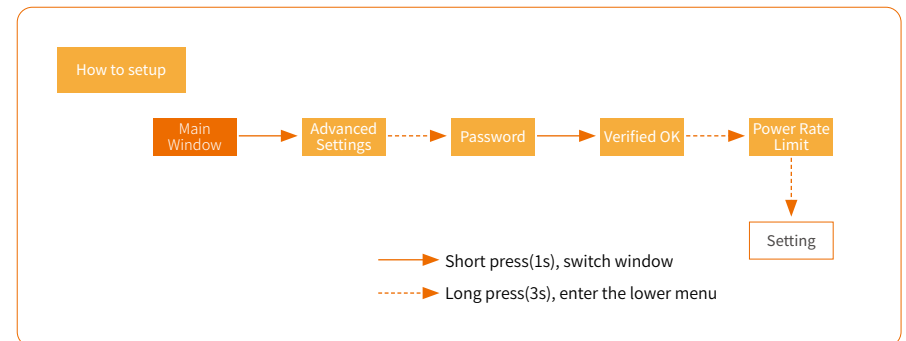
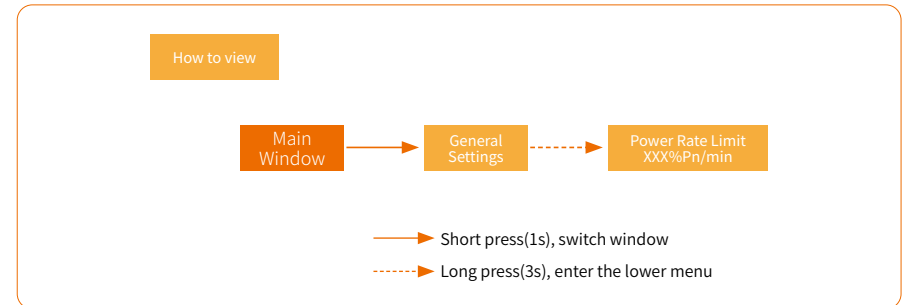

※ 6.7 Export Limit and Generation Limit

▼ 6.7.1 Export limit function setting

When the inverter is not equipped with “Export limit control” accessories, “Export Limit” function can be enabled.

Please set “Export Limit” under the menu “Export Limit” in “Advanced Settings”.

Please follow this flow chart to set “Export Limit”:

The “Export Limit” settings are password protected. User should be able to view but not edit the Export Limit. If you are installer, please contact importer for password. If there are any problems in the installation process, please call Sunways service telephone at +86400-9922-958 or email Sunways at service@sunways-tech.com for consultation.

Enable the Export Limit function by short pressing or long pressing the button on the inverter screen.

Set the percentage of the power that allowed to feed into grid, when set to XXX%, it means that the maximum power allowed to feed into grid is XXX% of the inverter’s rated output power. If you need Zero Export, set the percentage to 0%.

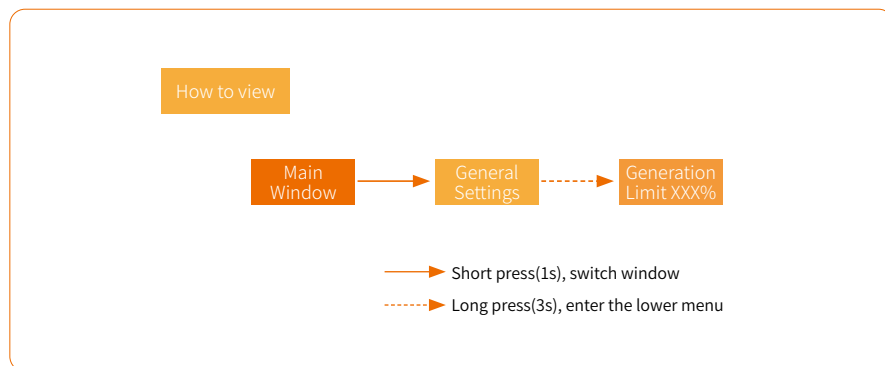

▼ 6.7.2 Generation limit setting

When the inverter is not equipped with “Export limit control” accessories, “Generation limit setting” function can be enabled.

Please set “Generation Limit ” under the menu “Generation Limit” in “Advanced Settings”.

Please follow this flow chart to set “Generation Limit”:

The “Generation Limit” settings are password protected. User should be able to view but not edit the Generation Limit. If you are installer, please contact importer for password. If there are any problems in the installation process, please call Sunways service telephone at +86400-9922-958 or email Sunways at service@sunways-tech.com for consultation.

Enable the Generation Limit function by short pressing or long pressing the button on the inverter screen.

Set the percentage of the power that allowed to output, when set to XXX%, it means that the maximum AC output power of inverter is XXX% of the inverter’s rated output power. If you need Zero output, set the percentage to 0%.

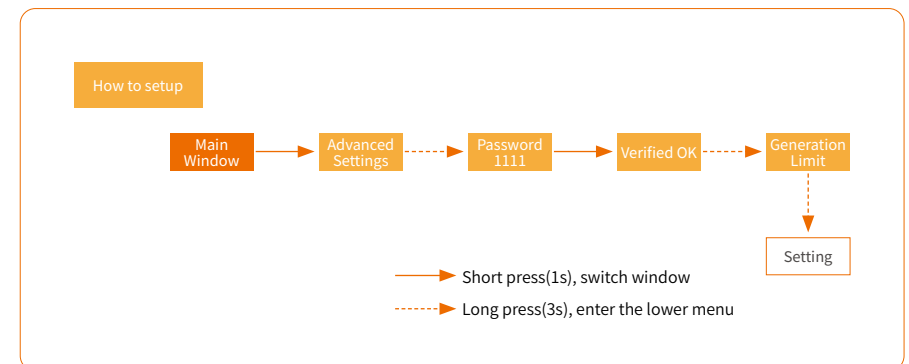
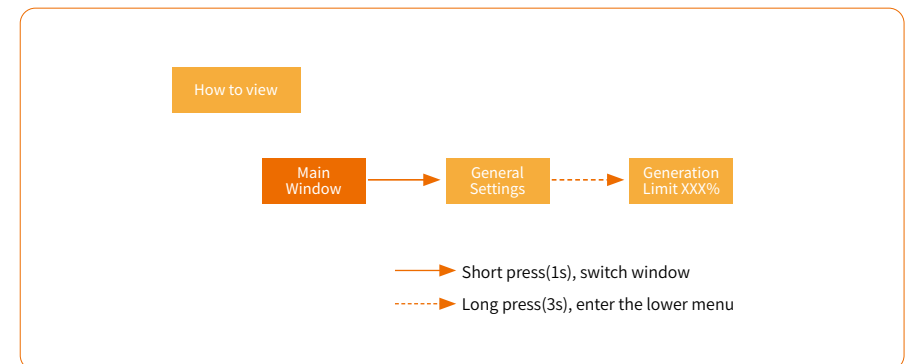

▼ 6.7.3 Soft export and hard export switch

During “Export Limit” setting and “Generation Limit” setting, the “Soft Export” mode and “Hard Export” mode can be switched in “Sys CtrlMode”.

Please follow this flow chart to switch the “Soft Export” mode and ”Hard Export”mode. This settings are password protected. User should be able to view but not edit. If you are installer, please contact importer for password. If there are any problems in the installation process, please call Sunways service telephone at +86400-9922-958 or email Sunways at service@sunways-tech.com for password.

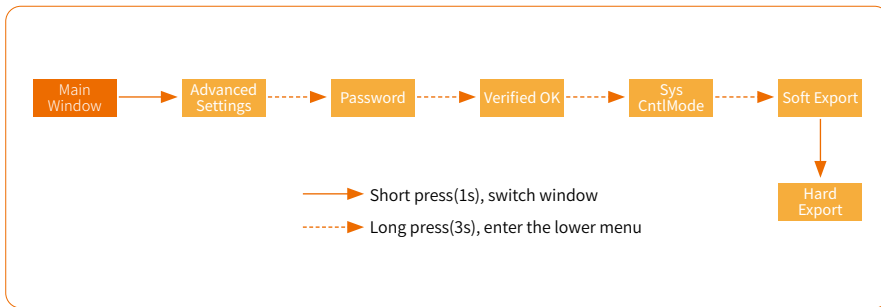

※ 6.8 Online Monitoring APP

Sunways inverter provides a monitoring port that can collect and transmit data from the inverter to Sunways monitoring platform via an external monitoring device. Please refer to the product nameplate on side of enclosure to get the monitoring application. If download issues exist , contact your dealer or Sunways technical support.

» 7 Troubleshooting

※ 7.1 Fault Messages

Sunways STH-3K~8KTL series single-phase hybrid inverter is designed in accordance with grid operation standard, and conform to the requirements of the safety and EMC. The inverter had passed a series of rigorous tests to ensure it runs sustainably and reliably before shipment. When a fault occurs, the corresponding fault messages will display on the OLED display, and in this case, the inverter might stop feeding into grid.

The fault messages and their corresponding troubleshooting methods are listed below:

Error Message	Solution
Mains Lost	① Check whether the mains supply is lost. ② Check whether the AC breaker and terminal are well connected.
Grid Voltage Fault	① Check whether the impedance of the AC cable is too high to lead the grid voltage increased. Change a thicker AC cable if it is. ② Extend the voltage protection range if it is allowed by the electricity company.
Grid Frequency Fault	① Check whether the AC cable is correct and well connected. ② Change to another country with wider protection range if it's allowed by the local electricity company.
DCI Fault	① Restart the inverter. ② Seek for help from the installer or manufacture.





Error Message	Solution
PV Power Low	<ol style="list-style-type: none"> ① Check if part of the PV array is sheltered. ② Check if the sunlight is sufficient at the PV installed area.
Bat OV	<ol style="list-style-type: none"> ① Check whether the battery voltage exceeds the upper limit of the battery. ② Check battery terminal wiring.
Backup OV	<ol style="list-style-type: none"> ① Restart the inverter. ② Check the inverter Backup side wiring.
Bus Volt Low	<ol style="list-style-type: none"> ① Restart the inverter. ② Seek for help from the installer or manufacture.
Hard Fault	<ol style="list-style-type: none"> ① Restart the inverter. ② Seek for help from the installer or manufacture.
Backup OP	<ol style="list-style-type: none"> ① Reduce loads connected in the Backup side. ② Restart the inverter.
Inverter OV	<ol style="list-style-type: none"> ① Restart the inverter. ② Seek for help from the installer or manufacture.

Error Message	Solution
Inverter OF	<ol style="list-style-type: none"> ① Restart the inverter. ② Seek for help from the installer or manufacture.
Inverter OC	<ol style="list-style-type: none"> ① Restart the inverter. ② Seek for help from the installer or manufacture.
Phase Order Err	<ol style="list-style-type: none"> ① Restart the inverter. ② Seek for help from the installer or manufacture.
SCI Fault	<ol style="list-style-type: none"> ① Restart the inverter. ② Seek for help from the installer or manufacture.
FLASH Fault	<ol style="list-style-type: none"> ① Restart the inverter. ② Seek for help from the installer or manufacture.
Meter Comm Fault	<ol style="list-style-type: none"> ① Check the Meter wiring. ② Check whether the Meter is normal.
Battery Fault	<ol style="list-style-type: none"> ① Restart the inverter. ② Seek for help from the installer or manufacture.

※ 7.2 PV System for Ground Faults

If ground fault occurs, the inverter will beep, the red LED will light up and the Error Message "GFCI Fault" will be displayed in the Results menu on the inverter user interface. At the same time, the Sunways monitoring system will also issue an alarm.

※ 7.3 Maintenance

 Danger	<p>Risk of inverter damage or personal injury due to incorrect service! Always keep in mind that the inverter is powered by dual sources: PV strings and utility grid. Before any service work, observe the following procedure.</p> <p>① Disconnect the AC circuit breaker and then set the DC load-break switch of the inverter to OFF; ② Wait at least 5 minutes for inner capacitors to discharge completely; ③ Verify that there is no voltage or current before pulling any connector.</p>
 Caution	<p>Keep non-related persons away! A temporary warning sign or barrier must be posted to keep non-related persons away while performing electrical connection and service work.</p>
 Attention	<p>Restart the inverter only after removing the fault that impairs safety performance. As the inverter contains no component parts that can be maintained, never arbitrarily replace any internal components. For any maintenance need, please contact Sunways. Otherwise, Sunways shall not be held liable for any damage caused.</p>
 Note	<p>Servicing of the device in accordance with the manual should never be undertaken in the absence of proper tools, test equipment or the latest revision of the manual which has been clearly and thoroughly understood.</p>

Items	Methods	Period
System clean	<p>Check the temperature and dust of the inverter. Clean the inverter enclosure if necessary. Check if the air inlet and outlet are normal. Clean the air inlet and outlet if necessary.</p>	Six months to a year (it depends on the dust contents in air.)

» 8 Technical Parameters

Model	STH-3KTL-HSS	STH-3.6KTL-HSS	STH-3KTL-HS	STH-3.6KTL-HS	STH-4.2KTL-HS
PV Input					
Start-up Voltage (V)	80	80	80	80	80
Max. DC Input Voltage (V)	600	600	600	600	600
Rated DC Input Voltage (V)	360	360	360	360	360
MPPT Voltage Range (V)	100-550	100-550	100-550	100-550	100-550
No. of MPP Trackers	1	1	2	2	2
No. of PV Inputs	1	1	1/1	1/1	1/1
Max. Input Current (A)	15	15	15/15	15/15	15/15
Max. Short-circuit Current (A)	20	20	20/20	20/20	20/20
Battery					
Battery Type	Lithium Battery (with BMS)				
Battery Communication Mode	CAN / RS485				
Battery Voltage Range (V)	85-500				
Max. Charge/Discharge Current (A)	30/30				
Rated Current of Built-in Fuse (A)	63				
Output (Grid)					
Rated Output Power (kW)	3	3.6	3	3.6	4.2
Max. Output Power (kW)	3.3	3.96	3.3	3.96	4.6
Max. Apparent Power (kVA)	3.3	3.96	3.3	3.96	4.6
Max. Input Apparent Power (kVA)	6 ^②	7.2 ^②	6 ^②	7.2 ^②	8.4 ^②
Max. Charging Power of Battery (kW)	3	3.6	3	3.6	4.2
Rated Output Voltage (V)	L/N/PE, 220/230V				
Rated AC Frequency (Hz)	50/60Hz				
Max. Output Current (A)	15	18	15	18	21
Power Factor	0.8 lead ing ... 0.8 lagging				
Max. Total Harmonic Distortion	<3% @Rated Output Power				
DCI	<0.5%In				
Output (Back-up)					
UPS Switching Time	<10ms				
Max. Apparent Output Power (kVA)	3.3	3.96	3.3	3.96	4.6
Peak Output Apparent Power (kVA)	3.9 ^③ , 60s	4.7 ^③ , 60s	3.9 ^③ , 60s	4.7 ^③ , 60s	5.5 ^③ , 60s
Voltage Harmonic Distortion	<3% @Linear Load				

Model	STH-3KTL-HSS	STH-3.6KTL-HSS	STH-3KTL-HS	STH-3.6KTL-HS	STH-4.2KTL-HS
Efficiency					
Max. Efficiency	97.6%	97.6%	97.6%	97.6%	97.6%
European Efficiency	97.0%	97.0%	97.0%	97.0%	97.0%
Battery Charged by PV Max. Efficiency	98.0%	98.0%	98.0%	98.0%	98.0%
Battery Charged by AC Max. Efficiency	96.6%	96.6%	96.6%	96.6%	96.6%
Max. Battery Discharge Conversion Efficiency	96.6%	96.6%	96.6%	96.6%	96.6%
Protection					
DC Reverse Polarity Protection	Integrated				
Battery Input Reverse Connection Protection	Integrated				
Insulation Resistance Protection	Integrated				
DC Switch	Integrated				
Surge Protection	Integrated				
Over-temperature Protection	Integrated				
Residual Current Protection	Integrated				
Islanding Protection	Frequency Shift, Integrated				
AC Over-voltage Protection	Integrated				
Overload Protection	Integrated				
AC Short-circuit Protection	Integrated				
General Data					
Over Voltage Category	PV: II ; Main: III				
Dimensions (mm)	550W*410H*175D				
Weight (kg)	26				
Protection Degree	IP65				
Self-consumption at Night (W)	<15				
Topology	Transformer-less				
Operating Temperature Range (° C)	-30~60				
Relative Humidity	0~100%				
Operating Altitude (m)	3000				
Cooling	Natural Convection				
Noise Level (dB)	<25				
Display	OLED & LED				
Communication	WiFi / LAN (Optional)				
Compliance	IEC62109、IEC62116、VDE4105、VDE0126、AS4777、RD1699、NBR16149、IEC61727、IEC60068、IEC61683、EN50549、EN61000				

Model	STH-4.6KTL-HS	STH-5KTL-HS	STH-6KTL-HS	STH-7KTL-HS	STH-8KTL-HS
PV Input					
Start-up Voltage (V)	80	80	80	80	80
Max. DC Input Voltage (V)	600	600	600	600	600
Rated DC Input Voltage (V)	360	360	360	360	360
MPPT Voltage Range (V)	100-550	100-550	100-550	100-550	100-550
No. of MPP Trackers	2	2	2	2	2
No. of PV Inputs	1/1	1/1	1/1	1/1	1/1
Max. Input Current (A)	15/15	15/15	15/15	15/15	15/15
Max. Short-circuit Current (A)	20/20	20/20	20/20	20/20	20/20
Battery					
Battery Type	Lithium Battery (with BMS)				
Battery Communication Mode	CAN / RS485				
Battery Voltage Range (V)	85-500				
Max. Charge/Discharge Current (A)	30/30				
Rated Current of Built-in Fuse (A)	63				
Output (Grid)					
Rated Output Power (kW)	4.6	5/4.99 ^①	6	7	8
Max. Output Power (kW)	4.6	5.5/4.99 ^{②③}	6.6	7.7	8
Max. Apparent Power (kVA)	4.6	5.5/4.99 ^③	6.6	7.7	8
Max. Input Apparent Power (kVA)	9.2 ^②	10 ^②	12 ^②	12 ^②	12 ^②
Max. Charging Power of Battery (kW)	4.6	5	6	7	8
Rated Output Voltage (V)	L/N/PE, 220/230V				
Rated AC Frequency (Hz)	50/60Hz				
Max. Output Current (A)	21	25/21.7 ^{③④}	28.7	35	36.3
Power Factor	0.8 leading ...0.8 lagging				
Max. Total Harmonic Distortion	<3% @Rated Output Power				
DCI	<0.5%In				
Output (Back-up)					
UPS Switching Time	<10ms				
Max. Apparent Output Power (kVA)	4.6	4.6	6.6	7.7	8
Peak Output Apparent Power (kVA)	6 ^⑤ , 60s	6 ^⑤ , 60s	7.8 ^⑤ , 60s	9.1 ^⑤ , 60s	10 ^⑤ , 60s
Voltage Harmonic Distortion	<3% @Linear Load				

Model	STH-4.6KTL-HS	STH-5KTL-HS	STH-6KTL-HS	STH-7KTL-HS	STH-8KTL-HS
Efficiency					
Max. Efficiency	97.6%	97.6%	97.6%	97.6%	97.6%
European Efficiency	97.0%	97.0%	97.0%	97.0%	97.0%
Battery Charged by PV Max. Efficiency	98.0%	98.0%	98.0%	98.0%	98.0%
Battery Charged by AC Max. Efficiency	96.6%	96.6%	96.6%	96.6%	96.6%
Max. Battery Discharge Conversion Efficiency	96.6%	96.6%	96.6%	96.6%	96.6%
Protection					
DC Reverse Polarity Protection	Integrated				
Battery Input Reverse Connection Protection	Integrated				
Insulation Resistance Protection	Integrated				
DC Switch	Integrated				
Surge Protection	Integrated				
Over-temperature Protection	Integrated				
Residual Current Protection	Integrated				
Islanding Protection	Frequency Shift, Integrated				
AC Over-voltage Protection	Integrated				
Overload Protection	Integrated				
AC Short-circuit Protection	Integrated				
General Data					
Over Voltage Category	PV: II ; Main: III				
Dimensions (mm)	550W*410H*175D				
Weight (kg)	26				
Protection Degree	IP65				
Self-consumption at Night (W)	<15				
Topology	Transformer-less				
Operating Temperature Range (° C)	-30~60				
Relative Humidity	0~100%				
Operating Altitude (m)	3000				
Cooling	Natural Convection				
Noise Level (dB)	<25				
Display	OLED & LED				
Communication	WiFi / LAN (Optional)				
Compliance	IEC62109、IEC62116、VDE4105、VDE0126、AS4777、RD1699、NBR16149、IEC61727、IEC60068、IEC61683、EN50549、EN61000				

- ① The grid feed in power for AS/NZS 4777.2 is limited 4.99kW & 4.99kVA & 21.7A.
- ② Max apparent power from the grid means the maximum power imported from the utility grid used to satisfy the backup loads and charge the battery.
- ③ The output power will exceed the rated value only when the power in the PV array is sufficient, and the duration of the overload is relating to the overload power.
- ④ 5000W for the regulation of C10/11
- ⑤ 21.7A for the regulation of C10/11

sunways

📍 No. 1, Second Road, Green Industrial Zone, Chongshou Town,
Cixi City, ZheJiang Province, PRC

🌐 www.sunways-tech.com

✉ service@sunways-tech.com

